

## Installation and operating guidelines

The Wykamol SumpFlo is a range of fully automatic waste water pump station, suitable for pumping ground water from a cavity membrane system and/or surface water from lightwells to a higher level.

### Models

SumpFlo

SumpFloTwin (single discharge)

SumpFloTwin (twin discharge)

SumpFlo BBPS (single discharge)

SumpFlo BBPS (twin discharge)

SumpFloTwin BBPS (twin discharge)



# Wykamol SumpFlo™

## 1. Contents

1	Content .....	2
2	Product summary .....	3
2.1	SumpFlo .....	3
2.2	SumpFloTwin .....	3
2.3	SumpFlo BBPS (battery backup system).....	3
2.4	SumpFloTwin BBPS (battery backup system) .....	4
3	Site preparation and installation.....	4
3.1	Advisory.....	4
3.2	Installation of SumpFlo (single pump configuration).....	5
3.3	Installation of SumpFloTwin (twin pump configuration, single discharge).....	8
3.4	Installation of SumpFloTwin (twin pump configuration, twin discharge configuration) .....	12
3.5	Installation of SumpFlo BBPS (twin pump configuration, single discharge configuration) .....	15
3.6	Installation of SumpFlo BBPS (twin pump configuration, twin discharge configuration).....	19
3.7	Installation of SumpFloTwin BBPS (twin pump configuration, twin discharge configuration).....	23
3.8	Electrical requirements.....	27
3.9	High level alarm (9V).....	27
3.10	AquaSafe Alarm.....	28
3.11	Battery backup pump system .....	28
3.11.1	Control panel operation.....	29
4	Technical specification .....	30
5	Dimensions.....	31
6	Parts list .....	32
7	Accessories .....	32
8	Electrical configuration .....	33
8.1	SumpFlo .....	33
8.2	SumpFloTwin.....	34
8.3	SumpFlo BBPS .....	35
8.4	SumpFloTwin BBPS .....	36
8	Wiring diagrams.....	37
9	Transport.....	38
10	Maintenance.....	38
11	Health and safety.....	39
11.1	Safety precautions.....	39
11.2	Electrical connections .....	39
11.3	Earthing .....	40
12	Guarantee.....	40
13	Service agreement.....	41
	Appendix A. How to prepare and solvent weld PVC pipework and fittings .....	42

# Wykamol SumpFlo™

## 2. Product summary

The Wykamol SumpFlo is a range of fully automatic waste water pump station, suitable for pumping ground water from a cavity membrane system and/or surface water from lightwells to a higher level.

### 2.1 SumpFlo

The system comprises of a polyethylene chamber, stainless steel float bracket, 1¼" PVC internal pipework and a powerful 240V submersible pump. The system is very versatile, enabling the installer to locate inlets to their specifications.

An Access Cover can be purchased to installer specifications.

It is recommended that a High Level Alarm product is installed, which acts as a warning system to alert the end user if the water rises above the normal operating level within the chamber. High Level Alarm kits can be purchased to installer specifications.

### 2.2 SumpFloTwin

The system comprises of a polyethylene chamber, stainless steel float bracket, 1¼" PVC internal pipework and two powerful 240V submersible pump. The system is very versatile, enabling the installer to locate inlets to their specifications.

An Access Cover can be purchased to installer specifications.

It is recommended that a High Level Alarm product is installed, which acts as a warning system to alert the end user if the water rises above the normal operating level within the chamber. High Level Alarm kits can be purchased to installer specifications.

1¼" PVC pipework configuration is available in single and twin discharge options, upon request.

### 2.3 SumpFlo BBPS (battery backup system)

The system comprises of a polyethylene chamber, stainless steel float bracket, 1¼" PVC internal pipework, a powerful 240V submersible pump, 24V Battery Backup pump and Battery Backup Control Panel complete with integrated High Level Alarm. The system is very versatile, enabling the installer to locate inlets to their specifications.

The system comes complete with a battery backup pump system, which is designed especially for where the possibility of primary 240V pump failure through either a pump fault or loss of mains power would be catastrophic. The system acts as a backup that will alert the end user if the water rises above the normal operating level within the chamber and will activate the 24V backup pump. The system is designed to activate via three separate float switches. The panel contains two batteries that are trickle charged, that will keep the backup system operational in situations of mains power failure (please refer to section 4.3 'Battery Backup Pump System' for details of battery life).

An Access Cover can be purchased to installer specifications.

1¼" PVC pipework configuration is available in single and twin discharge options, upon request.

# Wykamol SumpFlo™

## 2.4 SumpFloTwin BBPS (battery backup system)

The system comprises of a polyethylene chamber, stainless steel float bracket, 1¼" PVC internal pipework, two powerful 240V submersible pump, 24V Battery Backup pump and Battery Backup Control Panel complete with integrated High Level Alarm. The system is very versatile, enabling the installer to locate inlets to their specifications.

The system comes complete with a battery backup pump system, which is designed especially for where the possibility of primary/secondary 240V pump failure through either a pump fault or loss of mains power would be catastrophic. The system acts as a backup that will alert the end user if the water rises above the normal operating level within the chamber and will activate the 24V backup pump. The system is designed to activate via three separate float switches. The panel contains two batteries that are trickle charged, that will keep the backup system operational in situations of mains power failure (please refer to section 4.3 'Battery Backup Pump System' for details of battery life).

An Access Cover can be purchased to installer specifications.

## 3. Site preparation and installation

### 3.1 Advisory

It is important to note that these instructions are for guidance only and it is the installer's responsibility to satisfy themselves that the installation procedure is in accordance with the site conditions and good building practice, to eliminate any potential damage to the system either during or after installation. The installer should also satisfy themselves that the system can be install in conjunction with these guidelines, prior to work commencing.

The chamber is manufactured from polyethylene and as such is extremely robust. However, as with any preformed chamber they are susceptible to floatation and hydrostatic pressures exerted in high water table conditions.

Only qualified personnel should carry out the installation in accordance with the latest IET wiring regulations BS7671. All works should be in line with the Health and Safety at Works Act 1974.

Please read these instructions in full, prior to commencement of installation. If you are unsure on any point then ask for advice before proceeding. Our technical help desk is available on 01442 211554 from 08:30–17:30 Monday to Friday.

# Wykamol SumpFlo™

## 3.2 Installation of SumpFlo (single pump configuration). Pipework kit A.

1. Connection of the internal discharge pipe work within the chamber is as follows:

### Pipe Work Kit A (single pump configuration)

No.	Qty.	Part description	Qty supplied in Kit A	Part code
1	1	PVC 1 ¼" Male Threaded Adaptor	1	8023
2	1	PVC 1 ¼" Elbow PL/PL (90degree)	1	8022
3	1	PVC 1 ¼" Socket Union PL/PL	1	8027
4	1	PVC 1 ¼" Class E Pressure Pipe 0.5mtr	1	8024L
5	1	PVC 1 ¼" Tank Connector	1	8028
6	1	PVC 1 ¼" Coupling Female TH/TH	1	8030
7	1	32mm Male Iron	1	9010

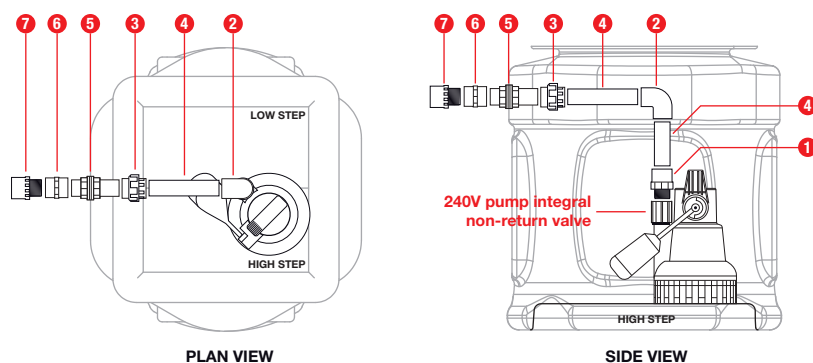

First select a suitable location for the pump ensuring that the float arm is not obstructed by for example the chamber wall, inlets etc, at its optimum reach. Remove the nut located in the pump switch and push the float arm into place ensuring that the nut is securely replaced. Prior to installing the internal pipe work please check the Non-Return Valve is securely fixed to the pump outlet and ensure that the flap opens in the direction of the flow.

- a) Using a 1 ¾" Hole Saw (44mm), cut a hole to dimensions of 495mm from base of chamber to hole centre, central location of the discharge flat facia, noting on the above drawing for step arrangement.
- b) Affix the supplied 1 ¼" PVC Tank Connector (part list position no. 5), with the male thread being fully externally located and placing the gasket seal internally between the internal locknut and chamber wall. Tighten Tank Connector PVC screwed lock nuts.
- c) Apply PTFE tape to the supplied Male Threaded Adaptor (part list position no. 1) and screw tightly into the Pump Integral Non-Return Valve female threaded outlet connection point.

# Wykamol SumpFlo™

- d) Position the Pump within the chamber on the high step, making sure the Male Threaded Adaptor is in direct line with the installed Tank Connector. Check that the Pump Float Arm is free from any obstruction at its optimum reach.
- e) Place the Socket Union (position no.3) over the plain end of the Tank Connector (do not use solvent glue at this stage).
- f) Measure and cut a length of horizontal Pipe required between the placed Socket Union (3) and Elbow (2) to be positioned directly above the Male Threaded Adaptor (1), taking into your measurement the length of pipe inserted into the fittings (do not use solvent glue at this stage).
- g) Measure and cut a length of vertical Pipe required between the placed Elbow (2) and Male Threaded Adaptor (1), taking into your measurement the length of pipe inserted into the fittings (do not use solvent glue at this stage).
- h) Chamfer, clean and dry the connection edges of the PVC lengths, using an appropriate PVC Solvent Cleaning Fluid, making sure these areas on the pipe and within the fitting are free from any debris/dirt.
- i) Check all the pipework is in place correctly before applying plenty of PVC Solvent Cement on required connections, wiping away any excess that may become visible with a clean cloth.
- j) For connection of the external discharge pipework, you will be left with a 1¼" PVC male thread on the outside of the chamber. We recommend that you use 1¼" Class E PVC Pressure Pipe, but should the installer wish to use 36mm OD Solvent Weld Waste Pipe (white), a PVC 1¼" Coupling Female TH/TH (6) and a 32mm Male Iron (7) is supplied within the fittings kit.

To apply these connections, apply PTFE tank to the male threads of the Tank Connector and Male Iron. Screw the 1¼" Coupling Female TH/TH (6) onto the Tank Connector, following the same process for the Male Iron into the Coupling.

Connection to be made with 36mm OD Solvent Weld Waste Pipe into the Male Iron would be as per point g) and h) as above.

2. Select a suitable location for the pumping station. It is extremely important to site the system with permanent access in mind for routine maintenance of the system.
3. Prepare the chamber for all connection, incoming pipe/s (inlet/s and cable duct). To do this you must select the location and drill the appropriate sized inlet/s and cable duct for the connections (see Section 7 Accessories' for inlet and cable duct rubber seals).
4. A reinforced waterproof concrete sump must be formed for the chamber to be installed within. This will ensure that any pressure present is not transferred onto the chamber itself. Furthermore, when constructing the reinforced waterproof concrete sump it is important that adequate space is made for connections to the chamber e.g. inlet/s, cable ducts and discharge. Consideration must also be made regarding the depth and orientation of all connections to ensure that they line up with the chamber.

It is imperative that you consult with a structural and waterproofing engineer when designing the reinforced waterproof concrete sump ensuring that it allows for the anticipated pressures and that they are not transferred onto the chamber.

# Wykamol SumpFlo™

5. In all instances, the chamber **MUST** be positioned on a flat, level, concrete base of dimensions sufficient to fully support the base of the chamber. Once the reinforced waterproof concrete sump has been formed, lay a 100mm mass concrete within your reinforced waterproof concrete sump, carefully position the chamber onto the WET concrete base ensuring that no loose debris is inadvertently knocked onto the base, under the chamber during this procedure. Push the chamber into the wet concrete ensuring that the concrete is fully imbedded into the bottom of the chamber. Position it such that the inlet/s, cable duct and discharge pipe work are correctly aligned.
6. Once the chamber is positioned, connect all pipes (inlet/s, cable duct and discharge) to the chamber.
7. Whilst the concrete base is still WET backfill the chamber with a mass concrete. The concrete must be evenly poured around the chamber ensuring that no voids are left within the concrete. Care must be taken to ensure that any pipes (or other connections) made, are not damaged. During the concrete pour, ensure that the chamber is vertical (by use of a spirit level across the chamber's opening). The chamber **MUST** be ballasted with water at the same rate as backfilling such that the level difference between the water and the backfill does not exceed 150mm at any time.

Please ensure that when pouring the concrete backfill, suitable steps are taken to prevent the concrete entering the chamber and any connected pipework.

8. The system is supplied with an access cover, this is loose and should sit directly above the top of the chamber access shaft. Please note that the chamber is only suitable for installation to a maximum of 300mm deeper than supplied from finished floor level.
9. Please note that the ballast water inside the chamber should not be removed until the backfill has fully cured.
10. It is recommended that an external gate valve (see Section 7 Accessories) be installed on the discharge line above slab level should the vertical lift exceed 3 meters.
11. It is extremely important that once the chamber has been installed, before the pump is installed, the system is flushed through and all sand, silt, rubble and general debris removed from the chamber.

**FAILURE TO DO THIS WILL INVALIDATE THE WARRANTY ON THE PUMPS.**

12. Install the pumps and water level monitoring cables and draw these cables through the cable duct back to the control equipment/electrical supply.
13. Commission the pumping station. A commissioning service is available, simply contact us on 01442 211554 for further information.



**Please refer to Appendix A for instructions on how to prepare and solvent weld PVC pipework and fittings.**

# Wykamol SumpFlo™

## 3.3 Installation of SumpFloTwin (twin pump configuration, single discharge). Pipework kits A+B.

1. Connection of the internal discharge pipe work within the chamber is as follows:

No.	Qty.	Part description	Qty supplied in Kit B	Part code
1	2	PVC 1 ¼" Male Threaded Adaptor	1	8023
2	2	PVC 1 ¼" Elbow PL/PL (90degree)	1	8022
3	3	PVC 1 ¼" Socket Union PL/PL	2	8027
4	2	PVC 1 ¼" Class E Pressure Pipe 0.5mtr	1	8024L
5	1	PVC 1 ¼" Tank Connector	0	8028
6	1	PVC 1 ¼" Coupling Female TH/TH	0	8030
7	1	32mm Male Iron	0	9010
8	1	PVC 1 ¼" Tee Piece	1	8032

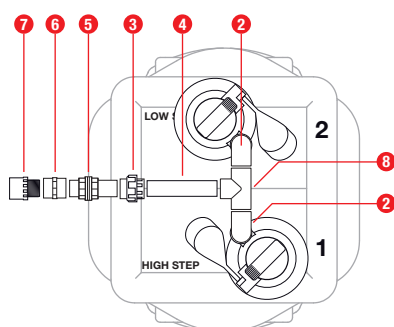

PLAN VIEW

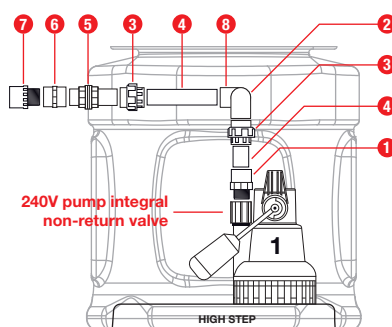

SIDE VIEW (L)

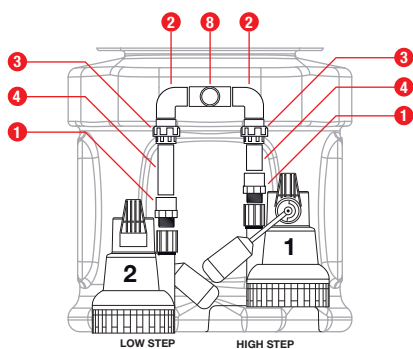

FRONT VIEW

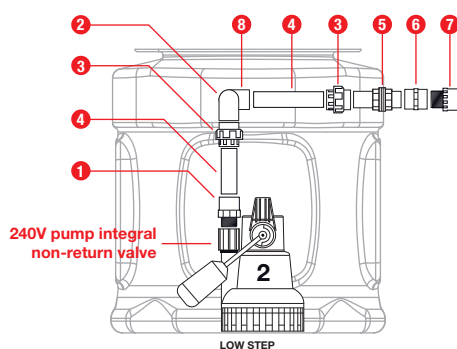

SIDE VIEW (R)



# Wykamol SumpFlo™

First select a suitable location for the pumps ensuring that 1no. pump is positioned on the base of the chamber and 1no. pump is positioned on the raised section. It is also essential to position the pumps so the float arms are not obstructed by for example the chamber wall, inlets etc, at their optimum reach (see diagram above). Remove the nut located in the pump switch and push the float arm into place ensuring that the nut is securely replaced. Prior to installing the internal pipe work please check the Non-Return Valves are securely fixed to the pump outlets and ensure that the flap opens in the direction of the flow.

- a) Using a 1 $\frac{3}{4}$ " Hole Saw (44mm), cut a hole to dimensions of 495mm from base of chamber to hole centre, central location of the discharge flat surface fascia, noting on the above drawing for step arrangement.
- b) Affix the supplied 1 $\frac{1}{4}$ " PVC Tank Connector (part list position no. 5), with the male thread being fully externally located and placing the gasket seal internally between the internal locknut and chamber wall. Tighten Tank Connector PVC screwed lock nuts.
- c) Apply PTFE tape to the supplied 2no. Male Threaded Adaptors (part list position no. 1) and screw tightly into the Pumps Integral Non-Return Valve female threaded outlet connection point.
- d) Position the Pumps within the chamber as per above diagram. Check that the Pump Float Arms are free from any obstruction at its optimum reach.
- e) Place the Socket Union (position no.3) over the plain end of the Tank Connector (do not use solvent glue at this stage).
- f) Measure and cut a length of horizontal Pipe required between the placed Socket Union (3) and Tee Piece (8) to be positioned above and between the Male Threaded Adaptors (1), taking into your measurement the length of pipe inserted into the fittings (do not use solvent glue at this stage).
- g) Measure and cut a length of link pipe for the Tee Piece (8) and Elbow (2) connections, noting that these fittings should be placed directly together (do not use solvent glue at this stage).
- h) Measure and cut a length of link pipe for the Elbow (2) and Socket Union (3) connections, noting that these fittings should be placed directly together (do not use solvent glue at this stage).
- i) Measure and cut a length of vertical Pipe required between the placed Socket Unions (2) and Male Threaded Adaptors (1), taking into your measurement the length of pipe inserted into the fittings (do not use solvent glue at this stage).
- j) Chamfer, clean and dry the connection edges of the PVC lengths, using an appropriate PVC Solvent Cleaning Fluid, making sure these areas on the pipe and within the fitting are free from any debris/dirt.
- k) Check all the pipework is in place correctly before applying plenty of PVC Solvent Cement on required connections, wiping away any excess that may become visible with a clean cloth.
- l) For connection of the external discharge pipework, you will be left with a 1 $\frac{1}{4}$ " PVC male thread on the outside of the chamber. We recommend that you use 1 $\frac{1}{4}$ " Class E PVC Pressure Pipe, but should the installer wish to use 36mm OD Solvent Weld Waste Pipe (white), a PVC 1 $\frac{1}{4}$ " Coupling Female TH/TH (6) and a 32mm Male Iron (7) is supplied within the fittings kit.

# Wykamol SumpFlo™

To apply these connections, apply PTFE tank to the male threads of the Tank Connector and Male Iron. Screw the 1¼" Coupling Female TH/TH (6) onto the Tank Connector, following the same process for the Male Iron into the Coupling.

Connection to be made with 36mm OD Solvent Weld Waste Pipe into the Male Iron would be as per point g) and h) as above.

2. Select a suitable location for the pumping station. It is extremely important to site the system with permanent access in mind for routine maintenance of the system.
3. Prepare the chamber for all connection, incoming pipe/s (inlet/s and cable duct). To do this you must select the location and drill the appropriate sized inlet/s and cable duct for the connections (see Section 7 Accessories' for inlet and cable duct rubber seals).
4. A reinforced waterproof concrete sump must be formed for the chamber to be installed within. This will ensure that any pressure present is not transferred onto the chamber itself. Furthermore, when constructing the reinforced waterproof concrete sump it is important that adequate space is made for connections to the chamber e.g. inlet/s, cable ducts and discharge. Consideration must also be made regarding the depth and orientation of all connections to ensure that they line up with the chamber.

It is imperative that you consult with a structural and waterproofing engineer when designing the reinforced waterproof concrete sump ensuring that it allows for the anticipated pressures and that they are not transferred onto the chamber.

5. In all instances, the chamber **MUST** be positioned on a flat, level, concrete base of dimensions sufficient to fully support the base of the chamber. Once the reinforced waterproof concrete sump has been formed, lay a 100mm mass concrete within your reinforced waterproof concrete sump, carefully position the chamber onto the WET concrete base ensuring that no loose debris is inadvertently knocked onto the base, under the chamber during this procedure. Push the chamber into the wet concrete ensuring that the concrete is fully imbedded into the bottom of the chamber. Position it such that the inlet/s, cable duct and discharge pipe work are correctly aligned.
6. Once the chamber is positioned, connect all pipes (inlet/s, cable duct and discharge) to the chamber.
7. Whilst the concrete base is still WET backfill the chamber with a mass concrete. The concrete must be evenly poured around the chamber ensuring that no voids are left within the concrete. Care must be taken to ensure that any pipes (or other connections) made, are not damaged. During the concrete pour, ensure that the chamber is vertical (by use of a spirit level across the chamber's opening). The chamber **MUST** be ballasted with water at the same rate as backfilling such that the level difference between the water and the backfill does not exceed 150mm at any time.

Please ensure that when pouring the concrete backfill, suitable steps are taken to prevent the concrete entering the chamber and any connected pipework.

8. The system is supplied with an access cover, this is loose and should sit directly above the top of the chamber access shaft. Please note that the chamber is only suitable for installation to a maximum of 300mm deeper than supplied from finished floor level.

# Wykamol SumpFlo™

9. Please note that the ballast water inside the chamber should not be removed until the backfill has fully cured.
10. It is recommended that an external gate valve (see Section 7 Accessories) be installed on the discharge line above slab level should the vertical lift exceed 3 meters.
11. It is extremely important that once the chamber has been installed, before the pump is installed, the system is flushed through and all sand, silt, rubble and general debris removed from the chamber.

**FAILURE TO DO THIS WILL INVALIDATE THE WARRANTY ON THE PUMPS.**

12. Install the pumps and water level monitoring cables and draw these cables through the cable duct back to the control equipment/electrical supply.
13. Commission the pumping station. A commissioning service is available, simply contact us on 01442 211554 for further information.



**Please refer to Appendix A for instructions on how to prepare and solvent weld PVC pipework and fittings.**

# Wykamol SumpFlo™

## 3.4 Installation of SumpFloTwin (twin pump configuration, twin discharge configuration). Pipework kits A+C.

1. Connection of the internal discharge pipe work within the chamber is as follows:

No.	Qty.	Part description	Qty supplied in Kit C	Part code
1	2	PVC 1 ¼" Male Threaded Adaptor	1	8023
2	2	PVC 1 ¼" Elbow PL/PL (90degree)	1	8022
3	2	PVC 1 ¼" Socket Union PL/PL	1	8027
4	2	PVC 1 ¼" Class E Pressure Pipe 0.5mtr	1	8024L
5	2	PVC 1 ¼" Tank Connector	1	8028
6	2	PVC 1 ¼" Coupling Female TH/TH	1	8030
7	2	32mm Male Iron	1	9010

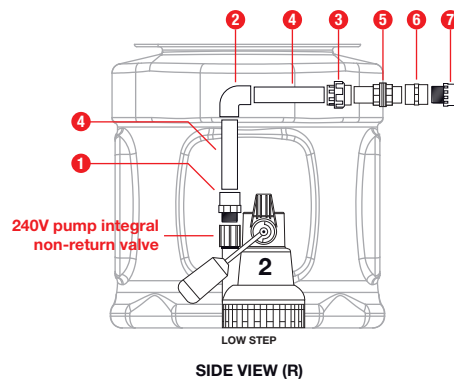
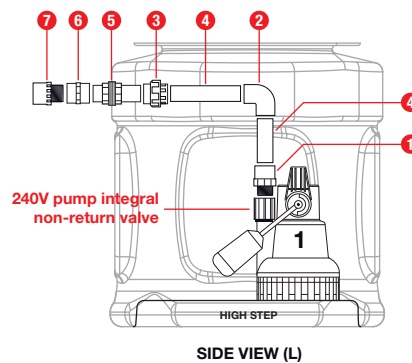
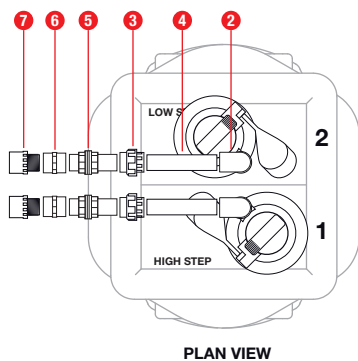

First select a suitable location for the pumps ensuring that 1no. pump is positioned on the base of the chamber and 1no. pump is positioned on the raised section. It is also essential to position the pumps so the float arms are not obstructed by for example the chamber wall, inlets etc, at their optimum reach (see diagram above). Remove the nut located in the pump switch and push the float arm into place ensuring that the nut is securely replaced. Prior to installing the internal pipe work please check the Non-Return Valves are securely fixed to the pump outlets and ensure that the flap opens in the direction of the flow.

# Wykamol SumpFlo™

- a) Using a 1½" Hole Saw (44mm), cut 2no. holes to dimensions of 495mm from base of chamber to hole centre, tank connector hole centres of 60mm from centre of the discharge flat surface fascia, noting on the above drawing for step arrangement.
  - b) For the primary pump to be located onto the higher step - Apply PTFE tape to the supplied Male Threaded Adaptor (part list position no. 1) and screw tightly into the Pump Integral Non-Return Valve female threaded outlet connection point.
  - c) Position the Pump within the chamber on the high step, making sure the Male Threaded Adaptor is in direct line with the installed Tank Connector. Check that the Pump Float Arm is free from any obstruction at its optimum reach.
  - d) Place the Socket Union (position no.3) over the plain end of the Tank Connector (do not use solvent glue at this stage).
  - e) Measure and cut a length of horizontal Pipe required between the placed Socket Union (3) and Elbow (2) to be positioned directly above the Male Threaded Adaptor (1), taking into your measurement the length of pipe inserted into the fittings (do not use solvent glue at this stage).
  - f) Measure and cut a length of vertical Pipe required between the placed Elbow (2) and Male Threaded Adaptor (1), taking into your measurement the length of pipe inserted into the fittings (do not use solvent glue at this stage).
  - g) For the secondary pump to be located on the lower step - Follow above steps b) through to f) until complete.
  - h) Chamfer, clean and dry the connection edges of the PVC lengths, using an appropriate PVC Solvent Cleaning Fluid, making sure these areas on the pipe and within the fitting are free from any debris/ dirt.
  - i) Check all the pipework is in place correctly before applying plenty of PVC Solvent Cement on required connections, wiping away any excess that may become visible with a clean cloth.
  - j) For connection of the external discharge pipework, you will be left with 2no. 1½" PVC male thread on the outside of the chamber. We recommend that you use 1½" Class E PVC Pressure Pipe, but should the installer wish to use 36mm OD Solvent Weld Waste Pipe (white), 2no. PVC 1½" Coupling Female TH/TH (6) and 2no. 32mm Male Iron (7) is supplied within the fittings kit.
2. Select a suitable location for the pumping station. It is extremely important to site the system with permanent access in mind for routine maintenance of the system.
  3. Prepare the chamber for all connection, incoming pipe/s (inlet/s and cable duct). To do this you must select the location and drill the appropriate sized inlet/s and cable duct for the connections (see Section 7 Accessories' for inlet and cable duct rubber seals).
  4. A reinforced waterproof concrete sump must be formed for the chamber to be installed within. This will ensure that any pressure present is not transferred onto the chamber itself. Furthermore, when constructing the reinforced waterproof concrete sump it is important that adequate space is made for connections to the chamber e.g. inlet/s, cable ducts and discharge. Consideration must also be made regarding the depth and orientation of all connections to ensure that they line up with the chamber.

# Wykamol SumpFlo™

It is imperative that you consult with a structural and waterproofing engineer when designing the reinforced waterproof concrete sump ensuring that it allows for the anticipated pressures and that they are not transferred onto the chamber.

5. In all instances, the chamber **MUST** be positioned on a flat, level, concrete base of dimensions sufficient to fully support the base of the chamber. Once the reinforced waterproof concrete sump has been formed, lay a 100mm mass concrete within your reinforced waterproof concrete sump, carefully position the chamber onto the WET concrete base ensuring that no loose debris is inadvertently knocked onto the base, under the chamber during this procedure. Push the chamber into the wet concrete ensuring that the concrete is fully imbedded into the bottom of the chamber. Position it such that the inlet/s, cable duct and discharge pipe work are correctly aligned.
6. Once the chamber is positioned, connect all pipes (inlet/s, cable duct and discharge) to the chamber.
7. Whilst the concrete base is still WET backfill the chamber with a mass concrete. The concrete must be evenly poured around the chamber ensuring that no voids are left within the concrete. Care must be taken to ensure that any pipes (or other connections) made, are not damaged. During the concrete pour, ensure that the chamber is vertical (by use of a spirit level across the chamber's opening). The chamber **MUST** be ballasted with water at the same rate as backfilling such that the level difference between the water and the backfill does not exceed 150mm at any time.

Please ensure that when pouring the concrete backfill, suitable steps are taken to prevent the concrete entering the chamber and any connected pipework.

8. The system is supplied with an access cover, this is loose and should sit directly above the top of the chamber access shaft. Please note that the chamber is only suitable for installation to a maximum of 300mm deeper than supplied from finished floor level.
9. Please note that the ballast water inside the chamber should not be removed until the backfill has fully cured.
10. It is recommended that an external gate valve (see Section 7 Accessories) be installed on the discharge line above slab level should the vertical lift exceed 3 meters.
11. It is extremely important that once the chamber has been installed, before the pump is installed, the system is flushed through and all sand, silt, rubble and general debris removed from the chamber.

## **FAILURE TO DO THIS WILL INVALIDATE THE WARRANTY ON THE PUMPS.**

12. Install the pumps and float switch and draw these cables through the cable duct back to the control equipment/ electrical supply.
13. Commission the pumping station. A commissioning service is available, simply contact us on 01442 211554 for further information.



**Please refer to Appendix A for instructions on how to prepare and solvent weld PVC pipework and fittings.**

# Wykamol SumpFlo™

## 3.5 Installation of SumpFlo BBPS (twin pump configuration, single discharge configuration). Pipework kits A+D.

1. Connection of the internal discharge pipe work within the chamber is as follows:

No.	Qty.	Part description	Qty supplied in Kit D	Part code
1	1	PVC 1 ¼" Male Threaded Adaptor	0	8023
2	3	PVC 1 ¼" Elbow PL/PL (90degree)	2	8022
3	3	PVC 1 ¼" Socket Union PL/PL	2	8027
4	2	PVC 1 ¼" Class E Pressure Pipe 0.5mtr	1	8024L
5	1	PVC 1 ¼" Tank Connector	0	8028
6	1	PVC 1 ¼" Coupling Female TH/TH	0	8030
7	1	32mm Male Iron	0	9010
8	1	PVC 1 ¼" Tee Piece	1	8032
9	3	PVC 1 ¼" PL/TH Barrel Nipple	3	8026
V	1	1 ¼" brass non-return valve supplied with full BBPS kit	0	-

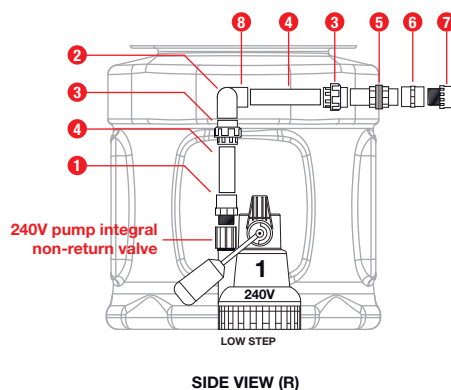
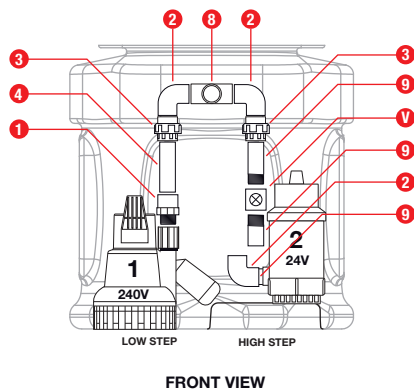
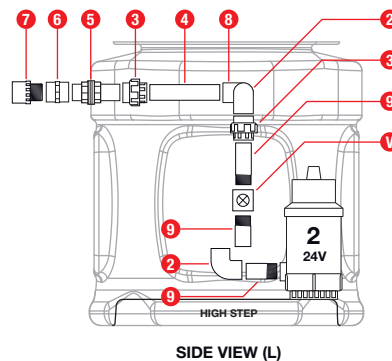
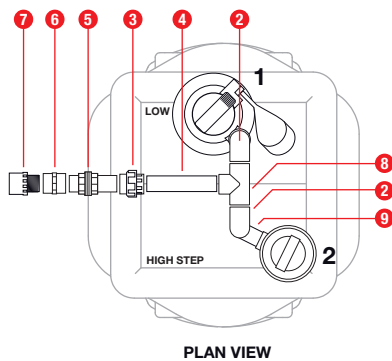

# Wykamol SumpFlo™

First position the Primary pump on the base of the chamber ensuring that the float arm is not obstructed by for example the chamber wall, inlets etc, at its optimum reach. Remove the nut located in the pump switch and push the float arm into place ensuring that the nut is securely replaced. Prior to installing the internal pipe work please check the Non-Return Valve is securely fixed to the pump outlet and ensure that the flap opens in the direction of the flow.

- a) Using a 1¼" Hole Saw (44mm), cut a hole to dimensions of 495mm from base of chamber to hole centre, central location of the discharge flat surface fascia, noting on the above drawing for step arrangement.
- b) Affix the supplied 1¼" PVC Tank Connector (part list position no. 5), with the male thread being fully externally located and placing the gasket seal internally between the internal locknut and chamber wall. Tighten Tank Connector PVC screwed lock nuts.
- c) For the primary pump to be located onto the lower step - Apply PTFE tape to the supplied Male Threaded Adaptor (part list position no. 1) and screw tightly into the Pump Integral Non-Return Valve female threaded outlet connection point.

- d) For the battery back up bilge pump to be located on the higher step – Apply PTFE tape to 3no. PL/TH Barrel Nipples (9).

Screw 1no. PL/TH Barrel Nipple (9) directly into the bilge pump horizontal outlet connection – do not overtighten.

Place 1no. Elbow (2) onto the PL/TH Barrel Nipple located into the bilge pump, transferring flow direction from horizontal to vertical.

Screw 2no. PL/Th Barrel Nipples (9) directly into the 1¼" Brass Non-Return Valve (V) supplied from the BBPS kit.

Place the Brass Non-Return Valve (V) complete with PL/TH Barrel Nipples, into the located Elbow (2), noting the flow direction arrow displayed on the Brass Non-Return Valve to be aligned correctly.

- e) Place a Socket Union (3) over the plain end of the Tank Connector (do not use solvent glue at this stage).
- f) Measure and cut a length of horizontal Pipe required between the placed Socket Union (3) and Tee Piece (8) to be positioned above and between the Pumps Connections, taking into your measurement the length of pipe inserted into the fittings (do not use solvent glue at this stage).
- g) Measure and cut a length of link pipe for the Tee Piece (8) and 2no. Elbow (2) connections, noting that these fittings should be placed directly together (do not use solvent glue at this stage).
- h) Measure and cut a length of link pipe for the Elbow (2) and Socket Union (3) connection for the Primary Pump, noting that these fittings should be placed directly together (do not use solvent glue at this stage).
- i) Measure and cut a length of vertical pipe for the Socket Union (3) and Male Threaded Adaptor (1) connection for the Primary Pump, taking into your measurement the length of pipe inserted into the fittings (do not use solvent glue at this stage).



# Wykamol SumpFlo™

- j) Place a Socket Union (3) onto the exposed PL/TH Barrel Nipple (9) coming from the 1¼" Brass Non-Valve (V) (do not use solvent glue at this stage).
- k) Measure and cut a length of vertical pipe for the Elbow (2) and Socket Union (3) connection for the Bilge Pump, taking into your measurement the length of pipe inserted into the fittings (do not use solvent glue at this stage).
- l) Chamfer, clean and dry the connection edges of the PVC lengths, using an appropriate PVC Solvent Cleaning Fluid, making sure these areas on the pipe and within the fitting are free from any debris/dirt.
- m) Check all the pipework is in place correctly before applying plenty of PVC Solvent Cement on required connections, wiping away any excess that may become visible with a clean cloth.
- n) For connection of the external discharge pipework, you will be left with a 1¼" PVC male thread on the outside of the chamber. We recommend that you use 1¼" Class E PVC Pressure Pipe, but should the installer wish to use 36mm OD Solvent Weld Waste Pipe (white), a PVC 1¼" Coupling Female TH/TH (6) and a 32mm Male Iron (7) is supplied within the fittings kit.

To apply these connections, apply PTFE tank to the male threads of the Tank Connector and Male Iron. Screw the 1¼" Coupling Female TH/TH (6) onto the Tank Connector, following the same process for the Male Iron into the Coupling.

Connection to be made with 36mm OD Solvent Weld Waste Pipe into the Male Iron would be as per point g) and h) as above.

2. Select a suitable location for the pumping station. It is extremely important to site the system with permanent access in mind for routine maintenance of the system.
3. Prepare the chamber for all connection, incoming pipe/s (inlet/s and cable duct). To do this you must select the location and drill the appropriate sized inlet/s and cable duct for the connections (see Section 7 Accessories' for inlet and cable duct rubber seals).
4. A reinforced waterproof concrete sump must be formed for the chamber to be installed within. This will ensure that any pressure present is not transferred onto the chamber itself. Furthermore, when constructing the reinforced waterproof concrete sump it is important that adequate space is made for connections to the chamber e.g. inlet/s, cable ducts and discharge. Consideration must also be made regarding the depth and orientation of all connections to ensure that they line up with the chamber.

It is imperative that you consult with a structural and waterproofing engineer when designing the reinforced waterproof concrete sump ensuring that it allows for the anticipated pressures and that they are not transferred onto the chamber.

5. In all instances, the chamber **MUST** be positioned on a flat, level, concrete base of dimensions sufficient to fully support the base of the chamber. Once the reinforced waterproof concrete sump has been formed, lay a 100mm mass concrete within your reinforced waterproof concrete sump, carefully position the chamber onto the WET concrete base ensuring that no loose debris is inadvertently knocked onto the base, under the chamber during this procedure. Push the chamber into the wet concrete ensuring that the concrete is fully imbedded into the bottom of the chamber. Position it such that the inlet/s, cable duct and discharge pipe work are correctly aligned.

# Wykamol SumpFlo™

6. Once the chamber is positioned, connect all pipes (inlet/s, cable duct and discharge) to the chamber.
7. Whilst the concrete base is still WET backfill the chamber with a mass concrete. The concrete must be evenly poured around the chamber ensuring that no voids are left within the concrete. Care must be taken to ensure that any pipes (or other connections) made, are not damaged. During the concrete pour, ensure that the chamber is vertical (by use of a spirit level across the chamber's opening). The chamber **MUST** be ballasted with water at the same rate as backfilling such that the level difference between the water and the backfill does not exceed 150mm at any time.

Please ensure that when pouring the concrete backfill, suitable steps are taken to prevent the concrete entering the chamber and any connected pipework.

8. The system is supplied with an access cover, this is loose and should sit directly above the top of the chamber access shaft. Please note that the chamber is only suitable for installation to a maximum of 300mm deeper than supplied from finished floor level.
9. Please note that the ballast water inside the chamber should not be removed until the backfill has fully cured.
10. It is recommended that an external gate valve (see Section 7 Accessories) be installed on the discharge line above slab level should the vertical lift exceed 3 meters.
11. It is extremely important that once the chamber has been installed, before the pump is installed, the system is flushed through and all sand, silt, rubble and general debris removed from the chamber.

**FAILURE TO DO THIS WILL INVALIDATE THE WARRANTY ON THE PUMPS.**

12. Install the pumps and float switch and draw these cables through the cable duct back to the control equipment/ electrical supply.
13. Commission the pumping station. A commissioning service is available, simply contact us on 01442 211554 for further information.



**Please refer to Appendix A for instructions on how to prepare and solvent weld PVC pipework and fittings.**

# Wykamol SumpFlo™

## 3.6 Installation of SumpFlo BBPS (twin pump configuration, twin discharge configuration). Pipework kits A+E.

1. Connection of the internal discharge pipe work within the chamber is as follows:

No.	Qty.	Part description	Qty supplied in Kit E	Part code
1	1	PVC 1 ¼" Male Threaded Adaptor	0	8023
2	3	PVC 1 ¼" Elbow PL/PL (90degree)	2	8022
3	3	PVC 1 ¼" Socket Union PL/PL	2	8027
4	2	PVC 1 ¼" Class E Pressure Pipe 0.5mtr	1	8024L
5	2	PVC 1 ¼" Tank Connector	1	8028
6	2	PVC 1 ¼" Coupling Female TH/TH	1	8030
7	2	32mm Male Iron	1	9010
8	3	PVC 1 ¼" PL/TH Barrel Nipple	3	8026
V	1	1 ¼" brass non-return valve supplied with full BBPS kit	0	-

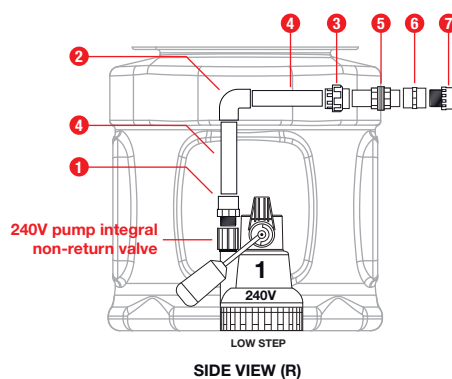
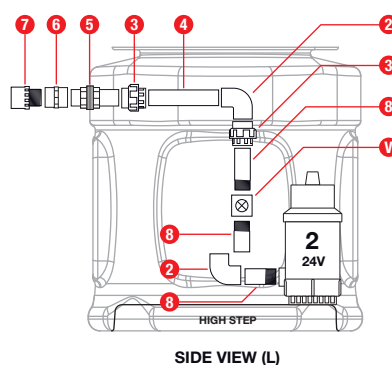
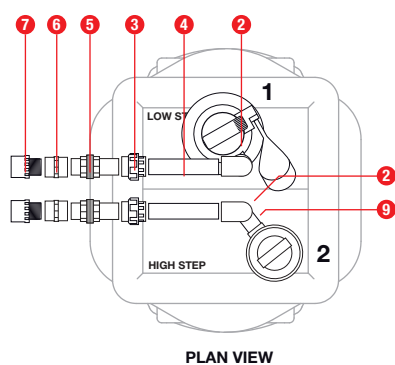

# Wykamol SumpFlo™

First position the Primary pump on the base of the chamber ensuring that the float arm is not obstructed by for example the chamber wall, inlets etc, at its optimum reach. Remove the nut located in the pump switch and push the float arm into place ensuring that the nut is securely replaced. Prior to installing the internal pipe work please check the Non-Return Valve is securely fixed to the pump outlet and ensure that the flap opens in the direction of the flow.

- a) Using a 1¼" Hole Saw (44mm), cut 2no. holes to dimensions of 495mm from base of chamber to hole centre, tank connector hole centres of 60mm from centre of the discharge flat surface fascia, noting on the above drawing for step arrangement.
- b) Affix the supplied 1¼" PVC Tank Connectors (part list position no. 5), with the male thread being fully externally located and placing the gasket seal internally between the internal locknut and chamber wall. Tighten Tank Connector PVC screwed lock nuts.
- c) For the primary pump to be located on the lower step - Apply PTFE tape to the supplied Male Threaded Adaptor (part list position no. 1) and screw tightly into the Pump Integral Non-Return Valve female threaded outlet connection point.
- d) Position the Primary Pump within the chamber on the lower step, making sure the Male Threaded Adaptor is in direct line with the installed Tank Connector. Check that the Pump Float Arm is free from any obstruction at its optimum reach.
- e) Place the Socket Union (position no.3) over the plain end of the Tank Connector relating to the Primary Pump pipework (do not use solvent glue at this stage).
- f) Measure and cut a length of horizontal Pipe required between the placed Socket Union (3) and Elbow (2) to be positioned directly above the Male Threaded Adaptor (1), taking into your measurement the length of pipe inserted into the fittings (do not use solvent glue at this stage).
- g) Measure and cut a length of vertical Pipe required between the placed Elbow (2) and Male Threaded Adaptor (1), taking into your measurement the length of pipe inserted into the fittings (do not use solvent glue at this stage).
- h) For the Battery Backup Bilge Pump to be located on the higher step - Apply PTFE tape to 3no. PL/TH Barrel Nipples (9).

Screw 1no. PL/TH Barrel Nipple (9) directly into the bilge pump horizontal outlet connection – do not overtighten.

Place 1no. Elbow (2) onto the PL/TH Barrel Nipple located into the bilge pump, transferring flow direction from horizontal to vertical.

Screw 2no. PL/Th Barrel Nipples (9) directly into the 1¼" Brass Non-Return Valve (V) supplied from the BBPS kit.

Place the Brass Non-Return Valve (V) complete with PL/TH Barrel Nipples, into the located Elbow (2), noting the flow direction arrow displayed on the Brass Non-Return Valve to be aligned correctly.

- i) Place the Socket Union (position no.3) over the plain end of the Tank Connector relating to the Bilge pump pipework(do not use solvent glue at this stage).

# Wykamol SumpFlo™

- j) Measure and cut a length of horizontal Pipe required between the placed Socket Union (3) and Elbow (2) to be positioned directly above the Socket Union (3), taking into your measurement the length of pipe inserted into the fittings (do not use solvent glue at this stage).
- k) Measure and cut a length of vertical Pipe required between the placed Elbow (2) and Socket Union (3), taking into your measurement the length of pipe inserted into the fittings (do not use solvent glue at this stage).
- l) Chamfer, clean and dry the connection edges of the PVC lengths, using an appropriate PVC Solvent Cleaning Fluid, making sure these areas on the pipe and within the fitting are free from any debris/ dirt.
- m) Check all the pipework is in place correctly before applying plenty of PVC Solvent Cement on required connections, wiping away any excess that may become visible with a clean cloth.
- n) For connection of the external discharge pipework, you will be left with 2no. 1¼" PVC male thread on the outside of the chamber. We recommend that you use 1¼" Class E PVC Pressure Pipe, but should the installer wish to use 36mm OD Solvent Weld Waste Pipe (white), 2no. PVC 1¼" Coupling Female TH/TH (6) and 2no. 32mm Male Iron (7) is supplied within the fittings kit.

To apply these connections, apply PTFE tank to the male threads of the Tank Connector and Male Iron. Screw the 1¼" Coupling Female TH/TH (6) onto the Tank Connector, following the same process for the Male Iron into the Coupling.

Connection to be made with 36mm OD Solvent Weld Waste Pipe into the Male Iron would be as per point g) and h) as above.

2. Select a suitable location for the pumping station. It is extremely important to site the system with permanent access in mind for routine maintenance of the system.
3. Prepare the chamber for all connection, incoming pipe/s (inlet/s and cable duct). To do this you must select the location and drill the appropriate sized inlet/s and cable duct for the connections (see Section 7 Accessories' for inlet and cable duct rubber seals).
4. A reinforced waterproof concrete sump must be formed for the chamber to be installed within. This will ensure that any pressure present is not transferred onto the chamber itself. Furthermore, when constructing the reinforced waterproof concrete sump it is important that adequate space is made for connections to the chamber e.g. inlet/s, cable ducts and discharge. Consideration must also be made regarding the depth and orientation of all connections to ensure that they line up with the chamber.

It is imperative that you consult with a structural and waterproofing engineer when designing the reinforced waterproof concrete sump ensuring that it allows for the anticipated pressures and that they are not transferred onto the chamber.

5. In all instances, the chamber MUST be positioned on a flat, level, concrete base of dimensions sufficient to fully support the base of the chamber. Once the reinforced waterproof concrete sump has been formed, lay a 100mm mass concrete within your reinforced waterproof concrete sump, carefully position the chamber onto the WET concrete base ensuring that no loose debris is inadvertently knocked onto the base, under the chamber during this procedure. Push the chamber into the wet concrete ensuring that the concrete is fully imbedded into the bottom of the chamber. Position it such that the inlet/s, cable duct and discharge pipe work are correctly aligned.

# Wykamol SumpFlo™

6. Once the chamber is positioned, connect all pipes (inlet/s, cable duct and discharge) to the chamber.
7. Whilst the concrete base is still WET backfill the chamber with a mass concrete. The concrete must be evenly poured around the chamber ensuring that no voids are left within the concrete. Care must be taken to ensure that any pipes (or other connections) made, are not damaged. During the concrete pour, ensure that the chamber is vertical (by use of a spirit level across the chamber's opening). The chamber **MUST** be ballasted with water at the same rate as backfilling such that the level difference between the water and the backfill does not exceed 150mm at any time.

Please ensure that when pouring the concrete backfill, suitable steps are taken to prevent the concrete entering the chamber and any connected pipework.

8. The system is supplied with an access cover, this is loose and should sit directly above the top of the chamber access shaft. Please note that the chamber is only suitable for installation to a maximum of 300mm deeper than supplied from finished floor level.
9. Please note that the ballast water inside the chamber should not be removed until the backfill has fully cured.
10. It is recommended that an external gate valve (see Section 7 Accessories) be installed on the discharge line above slab level should the vertical lift exceed 3 meters.
11. It is extremely important that once the chamber has been installed, before the pump is installed, the system is flushed through and all sand, silt, rubble and general debris removed from the chamber.

### **FAILURE TO DO THIS WILL INVALIDATE THE WARRANTY ON THE PUMPS.**

12. Install the pumps and float switch and draw these cables through the cable duct back to the control equipment/ electrical supply.
13. Commission the pumping station. A commissioning service is available, simply contact us on 01442 211554 for further information.



**Please refer to Appendix A for instructions on how to prepare and solvent weld PVC pipework and fittings.**

# Wykamol SumpFlo™

## 3.7 Installation of SumpFloTwin BBPS (twin pump configuration, twin discharge configuration). Pipework kit A+F.

1. Connection of the internal discharge pipe work within the chamber is as follows:

No.	Qty.	Part description	Qty supplied in Kit F	Part code
1	2	PVC 1 ¼" Male Threaded Adaptor	1	8023
2	3	PVC 1 ¼" Elbow PL/PL (90degree)	2	8022
3	4	PVC 1 ¼" Socket Union PL/PL	3	8027
4	4	PVC 1 ¼" Class E Pressure Pipe 0.5mtr	3	8024L
5	2	PVC 1 ¼" Tank Connector	1	8028
6	2	PVC 1 ¼" Coupling Female TH/TH	1	8030
7	2	32mm Male Iron	1	9010
8	1	PVC 1 ¼" Tee Piece	1	8032
9	3	PVC 1 ¼" PL/TH Barrel Nipple	3	8026
V	1	1 ¼" brass non-return valve supplied with full BBPS kit	0	-

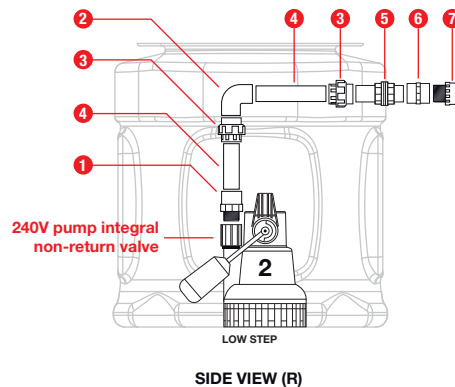
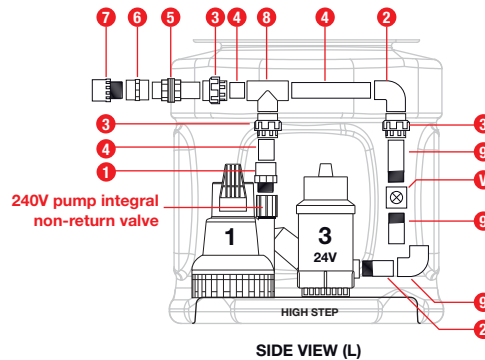
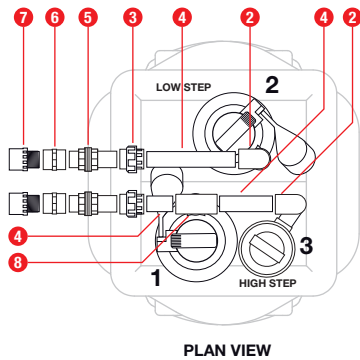

# Wykamol SumpFlo™

First position the Primary pump on the base of the chamber ensuring that the float arm is not obstructed by for example the chamber wall, inlets etc, at its optimum reach. Remove the nut located in the pump switch and push the float arm into place ensuring that the nut is securely replaced. Prior to installing the internal pipe work please check the Non-Return Valve is securely fixed to the pump outlet and ensure that the flap opens in the direction of the flow.

- a) Using a 1¼" Hole Saw (44mm), cut 2no. holes to dimensions of 495mm from base of chamber to hole centre, tank connector hole centres of 60mm from centre of the discharge flat surface fascia, noting on the above drawing for step arrangement.
- b) Affix the supplied 1¼" PVC Tank Connectors (part list position no. 5), with the male thread being fully externally located and placing the gasket seal internally between the internal locknut and chamber wall. Tighten Tank Connector PVC screwed lock nuts.
- c) For the primary pump to be located on the lower step - Apply PTFE tape to the supplied Male Threaded Adaptor (part list position no. 1) and screw tightly into the Pump Integral Non-Return Valve female threaded outlet connection point.
- d) Position the Primary Pump within the chamber on the lower step, making sure the Male Threaded Adaptor is in direct line with the installed Tank Connector. Check that the Pump Float Arm is free from any obstruction at its optimum reach.
- e) Place the Socket Union (position no.3) over the plain end of the Tank Connector relating to the Primary Pump pipework (do not use solvent glue at this stage).
- f) Measure and cut a length of horizontal Pipe required between the placed Socket Union (3) and Elbow (2) to be positioned directly above the Male Threaded Adaptor (1), taking into your measurement the length of pipe inserted into the fittings (do not use solvent glue at this stage).
- g) Measure and cut a length of vertical Pipe required between the placed Elbow (2) and Male Threaded Adaptor (1), taking into your measurement the length of pipe inserted into the fittings (do not use solvent glue at this stage).

- h) For the secondary pump and battery back up bilge pump to be located on the higher step –

Bilge Pump connection - Apply PTFE tape to 3no. PL/TH Barrel Nipples (9).

Screw 1no. PL/TH Barrel Nipple (9) directly into the bilge pump horizontal outlet connection – do not overtighten.

Place 1no. Elbow (2) onto the PL/TH Barrel Nipple located into the bilge pump, transferring flow direction from horizontal to vertical.

Screw 2no. PL/Th Barrel Nipples (9) directly into the 1¼" Brass Non-Return Valve (V) supplied from the BBPS kit.

Place the Brass Non-Return Valve (V) complete with PL/TH Barrel Nipples, into the located Elbow (2), noting the flow direction arrow displayed on the Brass Non-Return Valve to be aligned correctly.

Secondary Pump connection - Apply PTFE tape to the supplied Male Threaded Adaptor (part list position no. 1) and screw tightly into the Pump Integral Non-Return Valve female threaded outlet connection point.

- i) Place a Socket Union (3) over the plain end of the Tank Connector (do not use solvent glue at this stage).



# Wykamol SumpFlo™

- j) Measure and cut a length of horizontal Pipe required between the placed Socket Union (3) and Tee Piece (8). Tee Piece to be positioned above secondary pump Male Threaded Adaptor, taking into your measurement the length of pipe inserted into the fittings (do not use solvent glue at this stage).
- k) Measure and cut a length of link pipe for the Tee Piece (8) and 1no. Elbow (2) connection to the Bilge Pump, taking into your measurement the length of pipe inserted into the fittings (do not use solvent glue at this stage).
- l) Measure and cut a length of link pipe for the Elbow (2) and Socket Union (3) connection for the Secondary Pump, noting that these fittings should be placed directly together (do not use solvent glue at this stage).
- m) Measure and cut a length of vertical pipe for the Socket Union (3) and Male Threaded Adaptor (1) connection for the Secondary Pump, taking into your measurement the length of pipe inserted into the fittings (do not use solvent glue at this stage).
- n) Place a Socket Union (3) onto the exposed PL/TH Barrel Nipple (9) coming from the 1¼" Brass Non-Valve (V) (do not use solvent glue at this stage).
- o) Measure and cut a length of vertical pipe for the Elbow (2) and Socket Union (3) connection for the Bilge Pump, taking into your measurement the length of pipe inserted into the fittings (do not use solvent glue at this stage).
- p) Chamfer, clean and dry the connection edges of the PVC lengths, using an appropriate PVC Solvent Cleaning Fluid, making sure these areas on the pipe and within the fitting are free from any debris/dirt.
- q) Check all the pipework is in place correctly before applying plenty of PVC Solvent Cement on required connections, wiping away any excess that may become visible with a clean cloth.
- r) For connection of the external discharge pipework, you will be left with 2no. 1¼" PVC male thread on the outside of the chamber. We recommend that you use 1¼" Class E PVC Pressure Pipe, but should the installer wish to use 36mm OD Solvent Weld Waste Pipe (white), 2no. PVC 1¼" Coupling Female TH/TH (6) and 2no. 32mm Male Iron (7) is supplied within the fittings kit.

To apply these connections, apply PTFE tank to the male threads of the Tank Connector and Male Iron. Screw the 1¼" Coupling Female TH/TH (6) onto the Tank Connector, following the same process for the Male Iron into the Coupling.

Connection to be made with 36mm OD Solvent Weld Waste Pipe into the Male Iron would be as per point g) and h) as above.

- 2. Select a suitable location for the pumping station. It is extremely important to site the system with permanent access in mind for routine maintenance of the system.
- 3. Prepare the chamber for all connection, incoming pipe/s (inlet/s and cable duct). To do this you must select the location and drill the appropriate sized inlet/s and cable duct for the connections (see Section 7 Accessories' for inlet and cable duct rubber seals).
- 4. A reinforced waterproof concrete sump must be formed for the chamber to be installed within. This will ensure that any pressure present is not transferred onto the chamber itself. Furthermore, when constructing

# Wykamol SumpFlo™

the reinforced waterproof concrete sump it is important that adequate space is made for connections to the chamber e.g. inlet/s, cable ducts and discharge. Consideration must also be made regarding the depth and orientation of all connections to ensure that they line up with the chamber.

It is imperative that you consult with a structural and waterproofing engineer when designing the reinforced waterproof concrete sump ensuring that it allows for the anticipated pressures and that they are not transferred onto the chamber.

5. In all instances, the chamber **MUST** be positioned on a flat, level, concrete base of dimensions sufficient to fully support the base of the chamber. Once the reinforced waterproof concrete sump has been formed, lay a 100mm mass concrete within your reinforced waterproof concrete sump, carefully position the chamber onto the WET concrete base ensuring that no loose debris is inadvertently knocked onto the base, under the chamber during this procedure. Push the chamber into the wet concrete ensuring that the concrete is fully imbedded into the bottom of the chamber. Position it such that the inlet/s, cable duct and discharge pipe work are correctly aligned.
6. Once the chamber is positioned, connect all pipes (inlet/s, cable duct and discharge) to the chamber.
7. Whilst the concrete base is still WET backfill the chamber with a mass concrete. The concrete must be evenly poured around the chamber ensuring that no voids are left within the concrete. Care must be taken to ensure that any pipes (or other connections) made, are not damaged. During the concrete pour, ensure that the chamber is vertical (by use of a spirit level across the chamber's opening). The chamber **MUST** be ballasted with water at the same rate as backfilling such that the level difference between the water and the backfill does not exceed 150mm at any time.

Please ensure that when pouring the concrete backfill, suitable steps are taken to prevent the concrete entering the chamber and any connected pipework.

8. The system is supplied with an access cover, this is loose and should sit directly above the top of the chamber access shaft. Please note that the chamber is only suitable for installation to a maximum of 300mm deeper than supplied from finished floor level.
9. Please note that the ballast water inside the chamber should not be removed until the backfill has fully cured.
10. It is recommended that an external gate valve (see Section 7 Accessories) be installed on the discharge line above slab level should the vertical lift exceed 3 meters.
11. It is extremely important that once the chamber has been installed, before the pump is installed, the system is flushed through and all sand, silt, rubble and general debris removed from the chamber.

### **FAILURE TO DO THIS WILL INVALIDATE THE WARRANTY ON THE PUMPS.**

12. Install the pumps and float switch and draw these cables through the cable duct back to the control equipment/ electrical supply.
13. Commission the pumping station. A commissioning service is available, simply contact us on 01442 211554 for further information.



**Please refer to Appendix A for instructions on how to prepare and solvent weld PVC pipework and fittings.**

# Wykamol SumpFlo™

## 3.8 Electrical requirements

A qualified person in accordance with the Institute of Electrical Engineers Regulations should connect the Submersible Pumps, 24V Battery Backup System and AquaSafe Alarm to the mains supply taking into account all the electrical information provided.

1. Each device (as defined above) should be connected to its own 230V unswitched fused spur. Fuse to be suitably sized based on the electrical specifications as detailed under Technical Specification (see section 4).
2. Each unswitched fused spur to be powered from its own dedicated breaker within the distribution board. Breaker to be suitably sized based on the electrical specifications as detailed under Technical Specification (see section 4).
3. Ensure that the appropriate breaker within the distribution board is clearly marked for isolation of the connected device.
4. Please ensure that there is suitable slack on the cable to allow for the pump/s to be removed for maintenance.  
  
All unswitched fused spurs should be sited adjacent to the pumps / control panels. The unswitched fused spurs for the pumps should be minimum of 1 metre above the top of the pump station chamber.
5. Please refer to Electrical Configuration (see section 8).
6. This work should be entrusted to a qualified electrician in accordance with the latest IET wiring regulations BS7671.
7. Keep the connection isolated until you are ready to test the system.

**L** Live (Brown)  
**N** Neutral (Blue)  
**E** Earth (Green/Yellow)

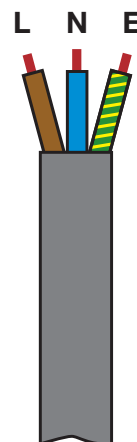

## 3.9 High level alarm (9V)

1. Remove the 2 screws from the back of the sounder module and insert a 9 volt battery (alkaline recommended), being sure to press the clips firmly in place (battery not included).
2. Reassemble ensuring the 2 screws are firmly in place.
3. Press blue test bar and hold for 2 seconds. If the unit is properly assembled, the alarm buzzer will sound.
4. Use the suction cup to attach the sensor to the upper part of the chamber ensuring that the activation of the pump is below the sensor. The buzzer will sound when water reaches the 2 metal contacts on the sensor.
5. The alarm sensor's buzzer may continue to sound even after it has been removed from the water. If so, remove the battery and allow the alarm sensor to dry for approximately 2 hours.

# Wykamol SumpFlo™

## 3.10 AquaSafe Alarm

Please refer to the AquaSafe Alarm Installation & Operating Guidelines.

## 3.11 Battery backup pump system

1. Select a suitable location for the control panel, taking into account that the panel must be located within 5m of the pump. It is important to bear in mind access to the control panel for maintenance purposes, ensuring it is located in a dry area and the audio alarm is audible to the end user.
2. Mount the panel to a wall or backboard using the mounting points at the back of the panel and appropriate screws and wall plugs (not supplied).
3. The three float switches need to be fixed to the metal bracket using the fittings provided (plastic washer and nut). Place the float switches into position ensuring that the activation arm is down and fixed into position using the plastic washer and nut.

The float switches should be located within the chamber ensuring that the following configuration is adhered to:

Float	Position
'Run' Float	Top of bracket
'High Level Alarm'	Float Middle of bracket (float is to be higher than the primary pump float switch).
'Off'	Float Bottom of bracket

4. The electrical/float cables should be drawn through the cable duct back to the control panel.
5. The panel should be connected to a 230V 13A unswitched fused spur.
6. Please ensure that there is suitable slack on the cable to allow for the pump to be removed for maintenance.
7. To commission the control panel you must connect both the batteries using the connectors provided, a red indicator on the battery charger will inform you that the batteries are now charging, once fully charged the red indicator will turn green. To test the system, disconnect power from the primary pump and fill the chamber with water until the backup pump activates. Please note that prior to the backup pump activating the high level alarm should sound.

# Wykamol SumpFlo™

## 3.11.1 Control panel operation

The most important element of the battery backup system is the control panel as it controls and monitors and status of the complete system.

The panel consists of both visual and audio indicators that are imperative for both the installer and end user to fully understand.

### Visual indicators

Indicator	Meaning
White Indicator (Supply On)	This indicates whether there is a mains supply connected to the unit. Should the mains supply be removed (i.e. Power failure, blown fuse) the light will go out.
Red Indicator (Fault)	This indicates that a fault is present within the Battery Backup System. Fault could be as pump has tripped (blockage), mains power is not present, or a battery fault. Please speak with your supplier or call Edincare Pumps on 01442 211554
Green Indicator (Running)	This indicates that the backup pump is in operation.
Large Red Indicator c/w Sounder (High Level Alarm)	This indicates that the water level within the pumping station is at an excessive level. A fault maybe present with the pumping station.

### Audio indicators

The battery backup system comes complete with an audio alarm to alert the user when there is a high level situation within the chamber. Also located on the front of the panel is an alarm mute button to silence the alarm in a high level situation.

Upon notification of this audio indicator, please check that the fault light is not illuminated on the control panel. It is also advisable that you check the mains supply to the 240V pump/s is present.

# Wykamol SumpFlo™

## 4. Technical specifications

### 4.1 SumpFlo, SumpFloTwin, SumpFlo BBPS and SumpFloTwin BBPS

Model	EA31 Pump	EA33 Pump
Power Supply	230V AC	230V AC
Rated Current	1.9A per pump	4.9A per pump
Motor Rating	180W per pump	500W per pump
Frequency	50Hz	50Hz
Revolutions Per Min.	2800rpm per pump	2800rpm per pump
Max Vertical Output	6.7m	12.5m
Max Flow Rate	2.9 l/s	3.9 l/s
Max Liquid Temp.	<50°C	<50°C
Discharge size	1¼" / 32mm	1¼" / 32mm
Free passage	10mm	10mm
Cable Length	5m	5m
Colour	Green	Green

### 4.2 Weight (excluding packaging)

Model	Weight (EA31 Pump)	Weight (EA33 Pump)
SumpFlo	14kg	16kg
SumpFloTwin (single discharge)	20kg	23kg
SumpFloTwin (twin discharge)	20kg	23kg
SumpFlo BBPS (single discharge)	30kg	33kg
SumpFlo BBPS (twin discharge)	30kg	33kg
SumpFlo BBPS Twin (twin discharge)	40kg	43kg

### 4.3 High level alarm (9V)

High level alarm (9V)	
Electrical input to alarm	9V
Electrical output from alarm	9V

# Wykamol SumpFlo™

## 4.4 AquaSafe Alarm

The system conforms to:

- The Low Voltage Directive, EN61010:2010
- The EMC Directive EN55014:2006, A1 and EN55014-2:2015

Model	AquaSafe Alarm
Power Supply	230V AC 50Hz
Rated Power	<10VA
Internal Battery	6V, 1.3AH
Sound Alarm Level	85dB
Main Power Cable Length	1m
Weight	0.5kg
Material	ABS
Colour	Grey
Operating Temperature	-10°C to +40°C

## 4.5 Battery backup pump system

Model	BBPS
Power supply to panel	230V AC
Power supply to pump (via panel)	24V
Frequency	50Hz
Motor rating	Intermittent
Max. vertical output	6.5m
Max flow rate	180l/m
Max. liquid temp.	<40°C
Rated current	13A
Discharge size	1¼" / 32mm
Cable length	4m
Battery life	30min

## 5. Dimensions

### 5.1 Chamber

Model	All models
Diameter	600mm
Height	600mm

### 5.2 High level alarm (9V)

Model	High level alarm
Height	90mm
Width	90mm
Depth	30mm

### 5.3 Battery backup panel

Model	BBPS
Height	380mm
Width	300mm
Depth	180mm

### 5.4 AquaSafe Alarm

Model	AquaSafe Alarm
Height	122mm
Width	124mm
Depth	85mm

# Wykamol SumpFlo™

## 6. Parts list

Product name	Quantity by pumping station					
	Sumpflo	SumpFloTwin (Single Discharge)	SumpfloTwin (Twin Discharge)	SumpFlo BBPS (Single Discharge)	SumpFlo BBPS (Twin Discharge)	SumpFloTwin BBPS (Twin Discharge)
Chamber	1	1	1	1	1	1
Stainless steel float bracket	1	1	1	1	1	1
240V pump (EA31/EA33)	1	2	2	1	1	2
240V pump float arm and locknut	1	2	2	1	1	2
240V pump integral non-return valve	1	2	2	1	1	2
24V battery backup pump	0	0	0	1	1	1
Brass non-return valve	0	0	0	1	1	1
24V battery backup pump control panel	0	0	0	1	1	1
Mini float switch	0	0	0	3	3	3
1 1/4" PVC pipework kit	Kit A	Kit A & Kit B	Kit A & Kit C	Kit A & Kit D	Kit A & Kit E	Kit A & Kit F

## 7. Accessories

Product name	Weight	Product code
AquaSafe Alarm (Mini)	–	22070W
1 1/4" brass gate valve	–	10003
110mm rubber seal (drainage inlet)	–	17010
50mm rubber seal (inlet/cable duct)	–	17012
12V 7Ah battery	–	10122
Access cover, locking, solid top, 350 x 350mm (pedestrian duty)	9kg	18017
Access cover, locking, solid top, 450 x 450mm (pedestrian duty)	13kg	18010
Access cover, PP frame, 450 x 450mm (pedestrian duty)	3kg	18078
Access cover, sealed, locking, recessed, 450 x 450mm (pedestrian duty)	9kg	18011
Micro float switch	–	23020



# Wykamol SumpFlo™

## 8. Electrical configuration

### 8.1 SumpFlo

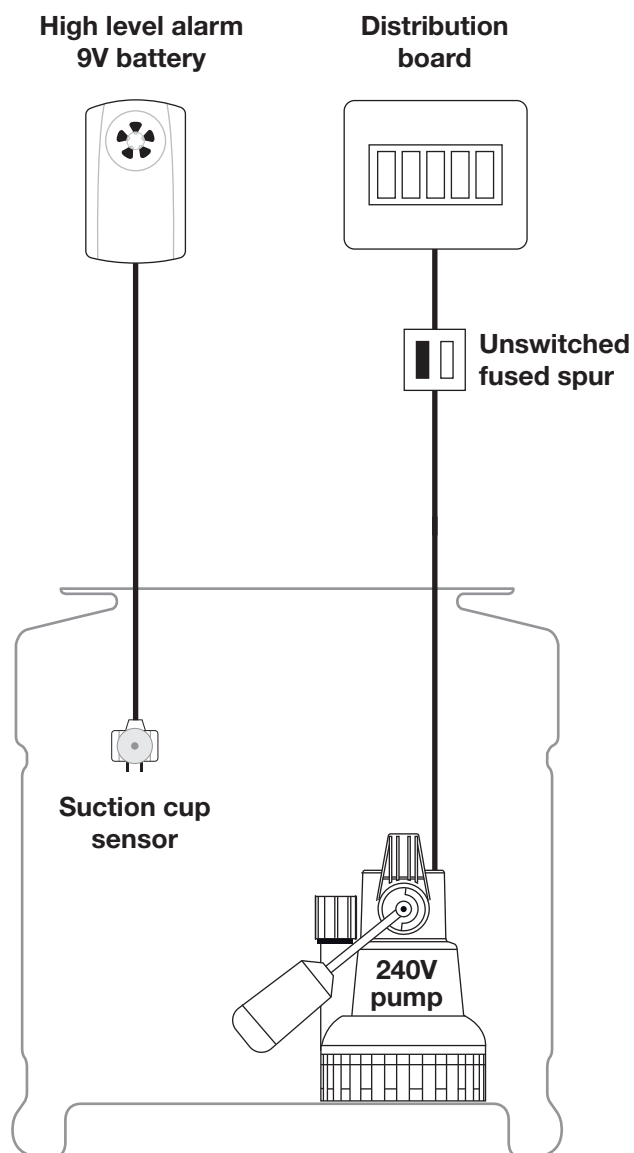

# Wykamol SumpFlo™

## 8.2 SumpFloTwin

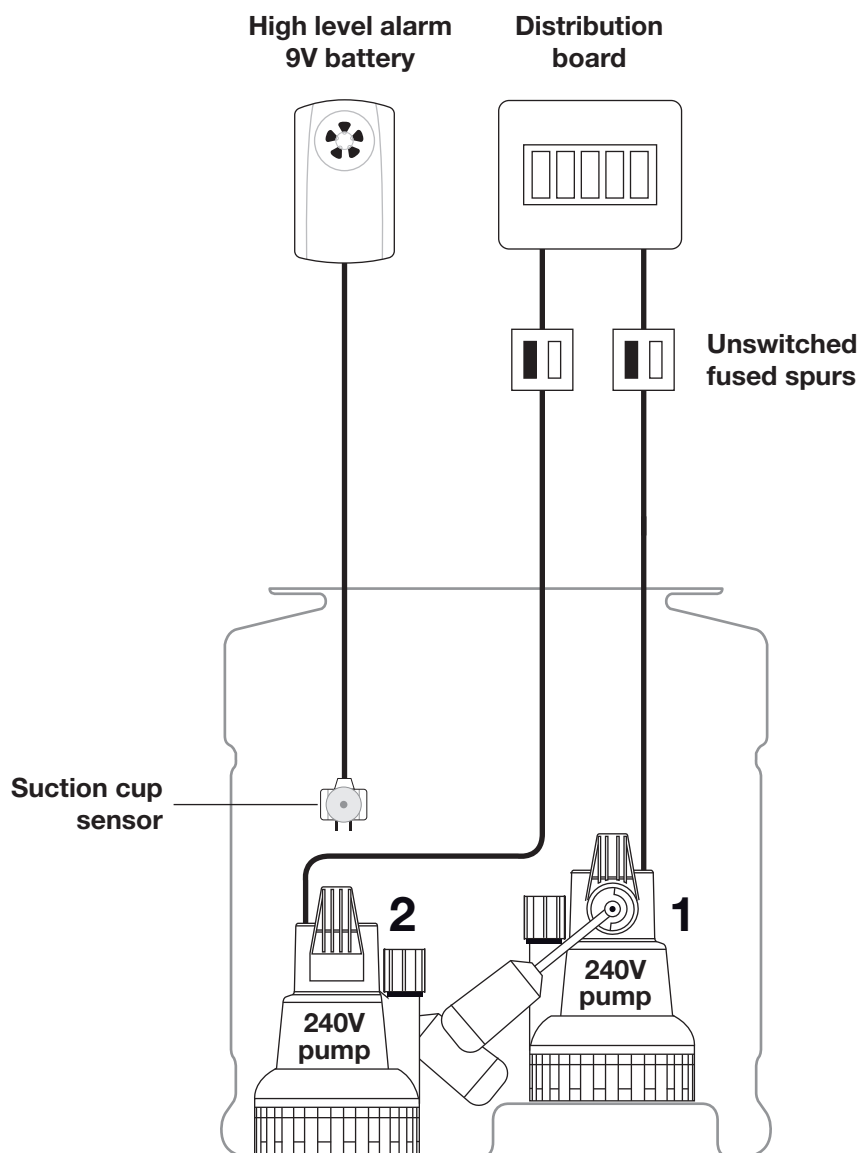

# Wykamol SumpFlo™

## 8.3 SumpFlo BBPS

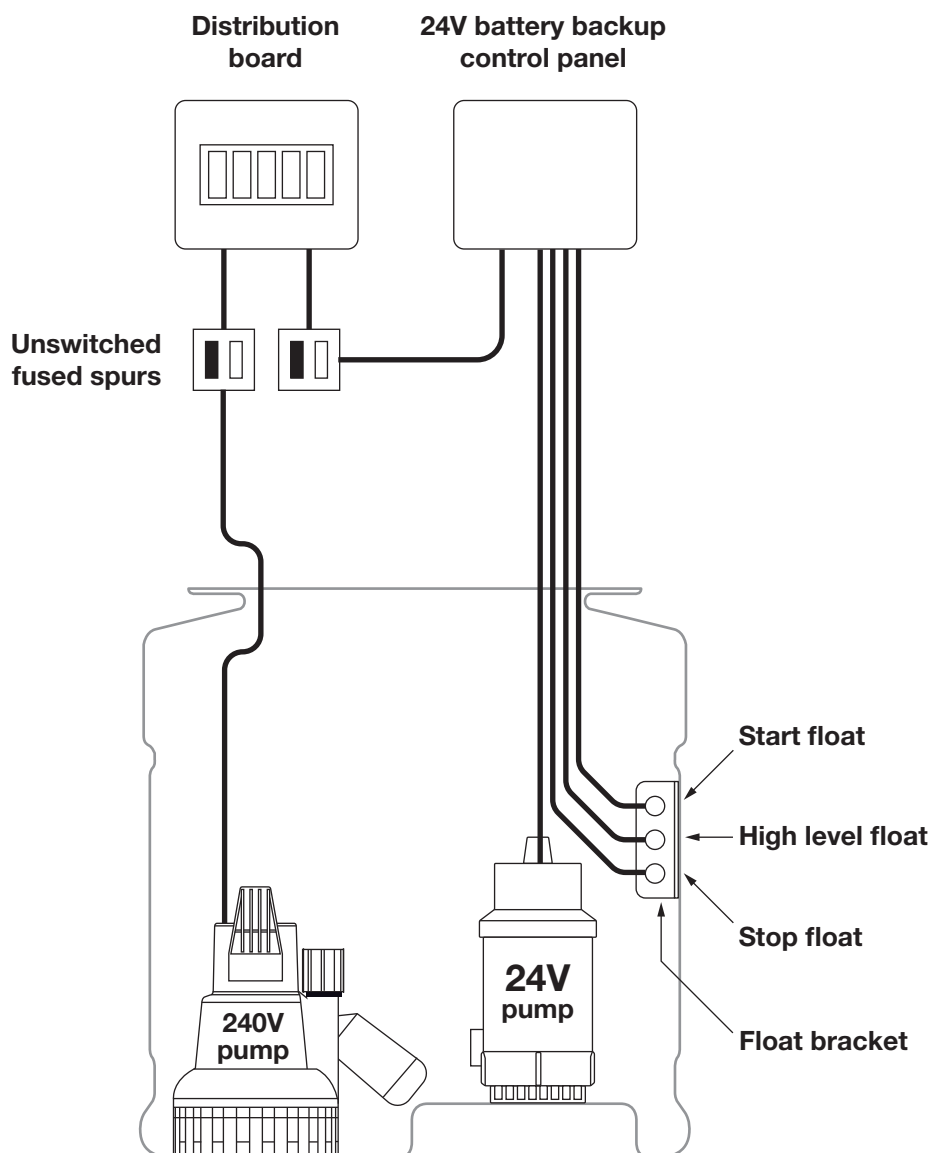

# Wykamol SumpFlo™

## 8.4 SumpFloTwin BBPS

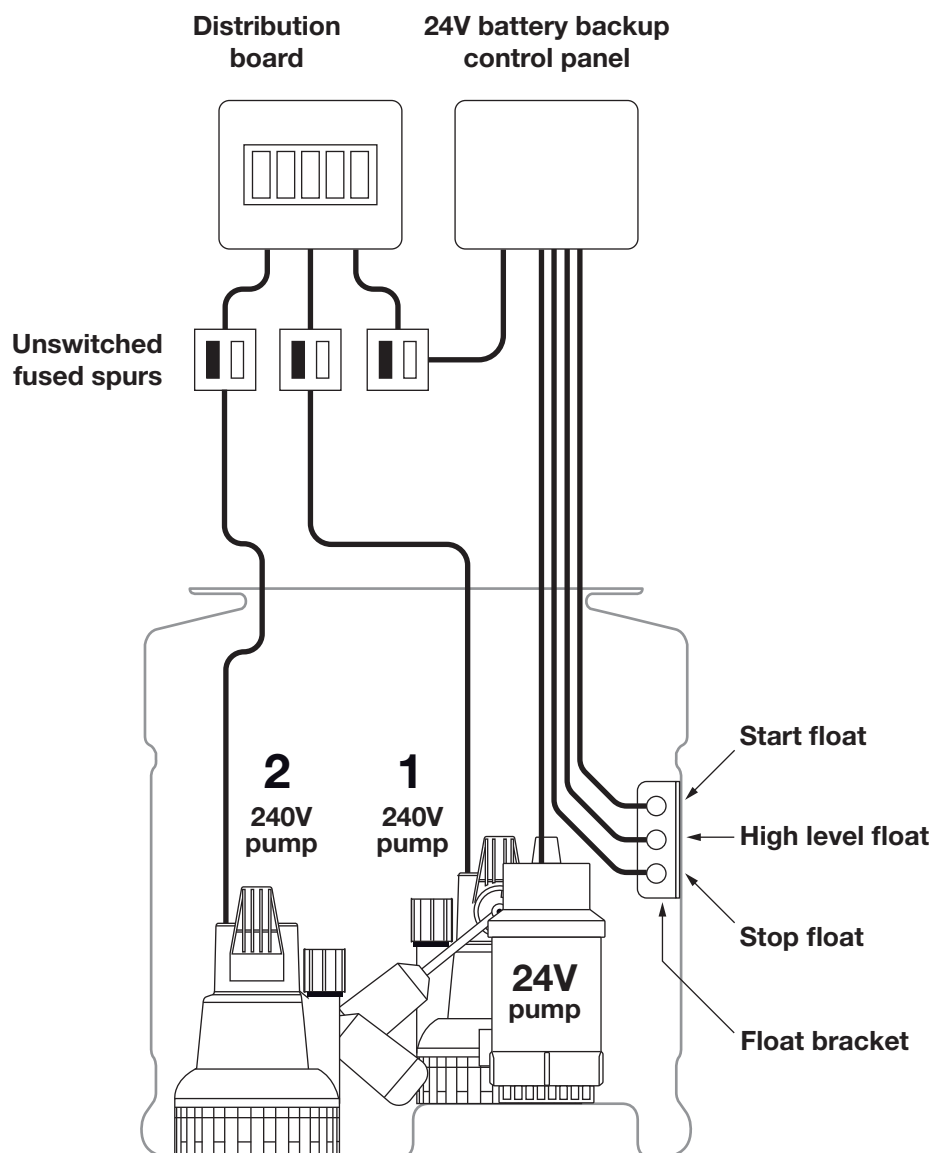

# Wykamol SumpFlo™

## 9. Wiring diagrams

Wiring Diagrams can be found within the panel control/s. Should you require further assistance please contact our technical helpdesk on 01442 211554 from 08:30–17:30, Monday to Friday.

### 9.1 Battery backup pump system

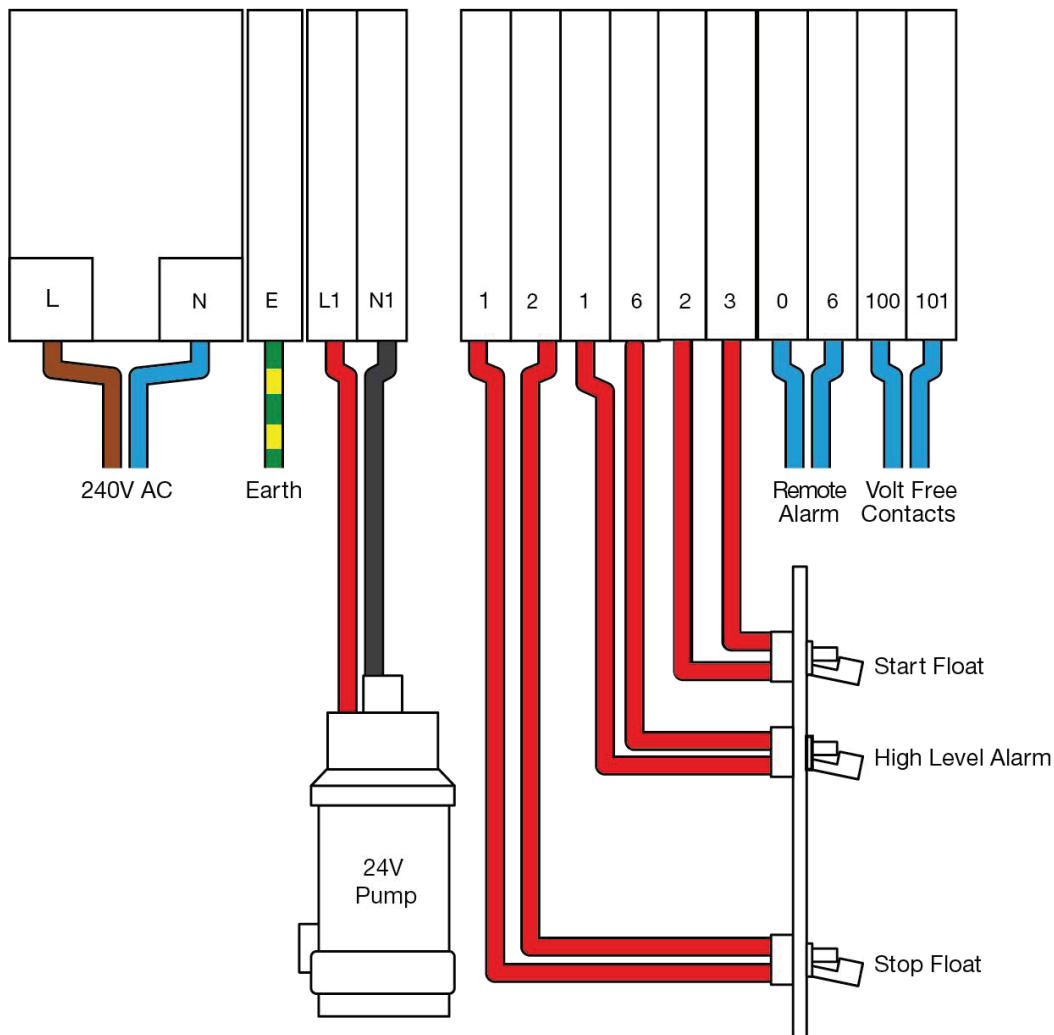

# Wykamol SumpFlo™

## 10. Transport

The pump/s are shipped disconnected from the pipe work and fittings to avoid damaged in transit.

Carefully unpack the product from its packing and inspect for any signs of damage. Should there be any damage present it must be reported immediately (no claim will be considered after 24hours from time of delivery).

Please refer to the parts list in Section 6.

## 11. Maintenance



**All maintenance works (inspections and services) MUST be undertaken by a technically qualified/ competent company/engineer.**

Please note that all batteries relating to high level alarms and battery backup systems must be replaced every 2 years.

When undertaking works within the chamber suitable measures MUST to taken to ensure safe access in accordance with current safety regulations. (see section 12).

Please refer to section 14 for further information on service agreements offered by Edincare Pumps.

To arrange a service please call our technical helpdesk on 01442 211554 from 8.30am–5.30pm, Monday to Friday or via email [aftersales@edincare.com](mailto:aftersales@edincare.com).

# Wykamol SumpFlo™

## 12. Health and safety

Please pay attention to the following regulations when installing the product or ask your qualified electrician/distributor.

### 12.1 Safety precautions

In order to minimise the risk of accidents in connection with the service and installation work the following rules should be followed:

- Make sure there are no poisonous gases within the work area.
- Check the explosion risk before using electric hand tools.
- Do not ignore health hazards.
- Observe strict cleanliness.
- Bear in mind the risk of electrical accidents.
- Make sure you have a clear path of retreat.
- Use a safety helmet, safety goggles and protective shoes.
- If working at height or in confined spaces, please ensure you meet the current health and safety regulations.
- A first aid kit must be close to hand.
- No unauthorised modifications should be made.
- Operation should be in accordance with this guide.

### 12.2 Electrical connections

Anyone carrying out electrical work must ensure that reasonable provision has been made in the design and installation of the electrical installations in order to protect any persons who might use, maintain or alter the electrical installation of that dwelling from fire and injury, including electric shock, this should be done in accordance with the latest IET wiring regulations BS7671.

- The following works should only be done by qualified and authorized electricians.
- Safeguard Europe disclaims all responsibility for work done by untrained or/and unauthorized personnel.
- Heed operating voltage (as shown in Section 4 and additional labels).
- Take out the main fuses to isolate the mains power supply from the control system before repairs or any other works and ensure it cannot be energized again.
- Before starting check the efficiency of the protective arrangements of the pump and the monitoring equipment. Failure to heed this warning may cause a lethal accident.
- Do not put the lead ends into water! Irruption of water may cause malfunctions.
- If persons are likely to come into physical contact with the pump or pumped media, the earthed (grounded) socket must have an additional connection to an earth (ground) fault protection device (GFI). (See earthing)
- Connection only to a mains power supply installed in accordance to the local regulations. Please consider the voltage drop of long supply cables.
- Replace the cable if the cable jacket is damaged. Do not pinch the cable or pull it around sharp bends.
- Always install the control unit in a dry and well-ventilated room above the backpressure level. Never install the control unit within the chamber.

# Wykamol SumpFlo™

## 12.3 Earthing

For safety reasons, the earth conductor should be approximately 50mm (2") longer than the phase conductors. If the motor cable is jerked loose by mistake, the earth conductor should be the last conductor to come loose from the first terminal. This applies to both ends of the cable. Ensure the correct earthing of the pump and control system.



**DO NOT OPEN THIS UNIT IF NOT QUALIFIED TO DO SO**

**To reduce the risk of electric shock, do not remove cover. No user-serviceable parts inside. Refer servicing to qualified service personnel.**

**DISCONNECT FROM MAINS BEFORE REMOVING COVER.**

## 13. Product guarantee

12-month guarantee (please refer to our Terms and Conditions for further information).

<https://www.edincare.com/general-information/terms-conditions/#Guarantee>



# Wykamol SumpFlo™

## 14. Service agreement

Our service agreements consist of planned preventive maintenance visits at an agreed frequency. As part of all service visits, a detailed service check list is utilised that covers all visual inspections, working tests, system adjustments and electrical safety checks.

Service agreement benefits:

- 10% discount off of all parts.
- Flexible payment options (Monthly Direct Debit).
- Service terms available between 2 – 5 years (discounts offered subject to service term).
- Out of hours service.
- Service visits to suit your schedule.
- Reduced emergency call out rates.
- Provide full reporting on all works undertaken, this includes current condition of equipment and any recommended works.
- Preferential scheduling of emergency call outs.
- Increased life expectancy of equipment.
- Reduced risk of breakdowns with their associated costs and inconvenience.
- Free technical advice available via our help line.
- Fully trained service engineers.
- Nationwide coverage.

Service visit intervals:

Please note; in accordance with BS EN 12056-4 and Edincare Pumps recommendations the pump equipment must be maintained at intervals of:

- Once per annum – Single residential dwelling
- Twice per annum – Single residential dwelling where there is a risk of flooding as a result of product failure (for example, basement applications) & Multiple residential dwellings
- Four times per annum – Commercial premises

A service agreement can be arranged by contacting Edincare Aftersales on 01442 211554 (option 2) and/or at [aftersales@edincare.com](mailto:aftersales@edincare.com)

## Appendix A. How to prepare and solvent weld PVC pipework and fittings

### A.1 Precautions

- The jointing area must be well ventilated
- Do not allow a naked flame or smoking in the jointing area
- Ensure cement is used prior to its expiry date (shown on bottom of tin)
- Wear rubber or latex gloves when applying MEK cleaner and PVC cement
- Never dilute PVC solvent cement
- Always replace lids on tins when not in use
- Always use clean brushes
- Always use clean lint-free cloth or absorbent paper
- Use a shelter to keep jointing surfaces dry in wet weather

### A.2 Solvent welding instructions

PVC cement is gap filling. PVC cement softens the inside of the fitting and the outside of the pipe to form a joint chemically. Strength of joint is reduced if surfaces are not cleaned and properly prepared.

1. Cut the pipe ends square.
2. Remove burrs and clean out swarf. A chamfer must be filed approx 3mm x 45° (This will prevent the layer of cement being scraped away as the pipe is pushed into the fitting).
3. Use a felt marker pen or pencil to mark the pipe at the distance which will penetrate the fitting socket to the root/stop.
4. Thoroughly clean the surfaces of both pipe and fittings with MEK cleaner on a clean lint-free cloth. Please note it is not necessary to abrade pipe or fitting unless pipes are discoloured/sun bleached.
5. Stir the PVC Cement thoroughly.
6. Use a clean brush approximately half as wide as the pipe to be jointed. Apply cement to the pipe and fittings using longitudinal strokes. The pipe should have a slightly thicker coating than the fitting. The prepared areas should be completely covered with cement.

Note: It is important to apply cement quickly to enable assembly without excessive force being required.

7. Immediately after application of cement push pipe fully home to the stop in the fitting without rotating. Hold the pipe and fitting for up to a minute, depending on size, to ensure fitting does not slide off the pipe.

Note: When working under cold conditions ensure the joints are free from frost and moisture and allow extra curing time.

8. Wipe off excess cement from both sides of the joint using a clean lint-free cloth.
9. Replace lids on tins.
10. Clean brush in MEK cleaner.

# Wykamol SumpFlo™

## A.3 Installing threaded fittings using PTFE tape

1. Ensure all threads are clean.
2. Apply PTFE Tape to the male thread for 1 1/2 turns in a clockwise direction.
3. Screw the female threaded fitting by hand onto the male thread.
4. It should be possible to screw the fitting on by hand for 2/3 of the thread length.
5. After tightening by hand add an extra 1/2 turn with a suitable tool i.e strap wrench.



### A.3.1 Precautions

Use PTFE Tape or Kolmat Fibre Tape/Paste. Do not force tightening of the joint under any circumstances.



Wykamol Group Ltd, Boran Court, Network 65 Business Park, Burnley, BB11 5TH

+44 (0)1282 473100  
info@wykamol.com  
www.wykamol.com

 [wykamol-group](#)  
 [wykamolgroup](#)  
 [wykamolgroupLtd](#)

Supplied in conjunction with

