

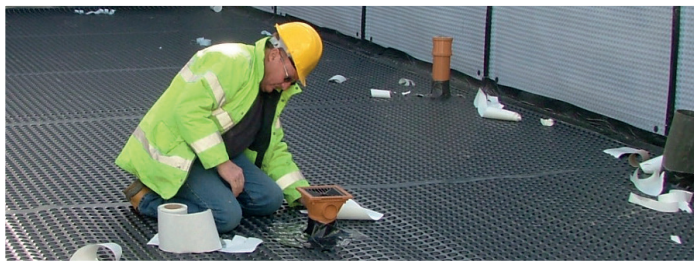

Pumped drainage systems for basement applications





A range of foul and ground systems suitable for basements



With over 70 years' experience, Wykamol can supply everything you need to ensure a successful job. We have a complete range of treatments, waterproof membrane, sump pumps and drainage systems.

Wykamol have teamed up with a major drainage specialist company to design a bespoke range of products for the basement conversion industry. The range includes products for both ground water and foul waste along with a host of backup solutions.

Wykamol Group

Unit 3, Boran Court,
Network 65 Business Park,
Hapton, Burnley,
Lancashire BB11 5TH
t: +44 (0)845 400 6666
f: +44 (0)845 400 3333
www.wykamol.com
salesdepartment@wykamol.com

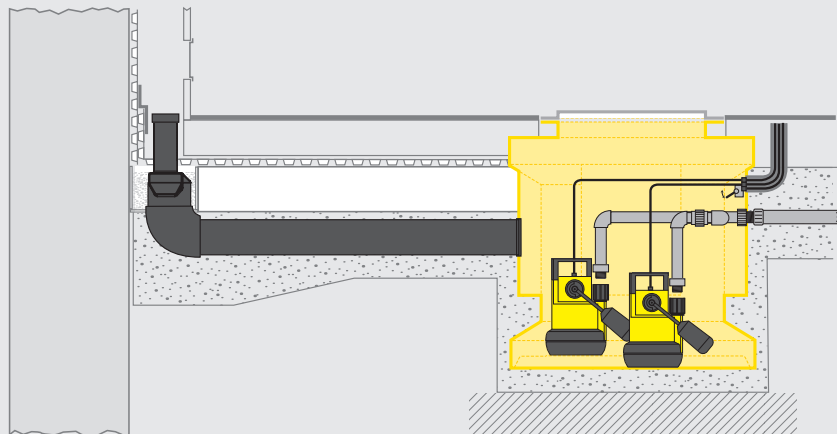

water pumped drainage in all applications.

Nationwide coverage

The Wykamol Group has a network of technical managers spread across the UK and Ireland. These managers are able to attend sites and give technical advice covering all our range of products.



Call 0845 400 66 66 to find your local representative.

Contents

4 Ground Water Systems

- 5 SumpFlo
- 6 SumpFlo Twin
- 7 SumpFlo BBPS
- 8 SumpFlo Twin BBPS
- 9 BlackSump
- 10 SumpFlo Pro
- 11 SumpFlo Pro Twin

12 Foul Water Systems

- 13 DrainFlo 150
- 14 DrainFlo 200
- 15 DrainFlo 360
- 16 DrainFlo 360 Twin

17 Above Ground Systems

- 18 PowerFlush
- 19 AquaFlush

20 High Level Alarms

- 21 High level alarm 9 volt
- 21 High level alarm (Mains Operated)
- 22 High level alarm (Mains & Battery Operated)
- 22 Basement monitoring systems & battery back up

23 Battery Back-up Systems

- 24 PowerSafe
- 25 UPS battery back-up
- 25 PowerFlo
- 26 Aftersales
- 27 Site specification form



Ground water systems

Our range of ground water pumping systems are specifically designed for the removal of ground water from basement membrane systems.

There are a variety of different models to suit most installations including single, twin and battery backup options along with a range of alarm options. The systems are very versatile, enabling the installer to locate inlets to their specifications.



ONE-YEAR GUARANTEE
Terms and conditions apply.



SERVICING
See page 26.

For additional information and prices visit

www.wykamol.com



t: +44 (0)845 400 6666 f: +44 (0)845 400 3333 salesdepartment@wykamol.com

SUMPFLO



The SumpFlo™ is specially designed for the removal of groundwater from basement cavity drainage membrane systems. The system comprises of a polyethylene tank, locking access cover (pedestrian duty, not suitable for roadways) and powerful submersible pump. The system is very versatile, enabling the installer to locate inlets to their specifications.

The system comes complete with a High Level Alarm (9V), which acts as a warning system to alert the end user if the water rises above the normal operating level within the tank. The alarm is designed to activate via a separate float switch.

MODELS

- SumpFlo (301)
- SumpFlo (303)

TECHNICAL DATA

MODEL	301	303
Power Supply	230V AC	230V AC
Rated Current	1.9A	4.9A
Motor Rating	180W	500W
Frequency	50Hz	50Hz
Revs Per Minute	2720rpm	2800rpm
Max. Vert. Output	7m	12m
Max. Horiz. Output	50m	100m
Max. Flow Rate	168l/m	240l/m
Max. Liquid Temp.	<40°C	<40°C
Discharge Size	32mm	32mm
Cable Length	5m	5m
Weight	14kg	14.5kg
Colour	Yellow	Yellow

PUMP CURVE

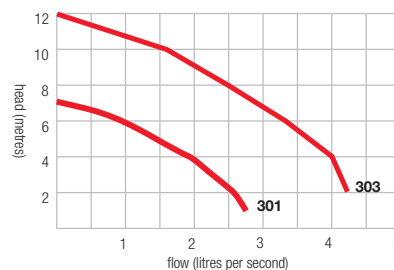

DIMENSIONS

MODEL	SUMPFLO
Height / Diameter (mm)	600 x 600
Clear opening (mm)	350 x 350

KEY FEATURES

- Easy to install
- Odour tight locking access cover
- Variable inlet positions
- Integral non-return valve preventing back flow
- Durable polyethylene tank
- Pre-moulded flotation points preventing movement below ground
- Integral step for dual pump setup
- Powerful submersible pump

Visit www.wykamol.com for full technical drawings

ACCESSORIES



High level alarm (mains)

High level alarm (mains & battery)

Basement monitoring system

110mm rubber seal inlet

50mm rubber seal inlet

Inlay access cover

Battery back-up

Telemetric system

SUMPFLO TWIN



Single discharge option

Twin discharge option

The SumpFloTwin™ is specially designed for the removal of groundwater from basement cavity drainage membrane systems. The system comprises of a polyethylene tank, locking access cover (pedestrian duty, not suitable for roadways) and two powerful submersible pumps. The system is very versatile, enabling the installer to locate inlets to their specifications.

The system comes complete with a High Level Alarm (9V), which acts as a warning system to alert the end user if the water rises above the normal operating level within the tank. The alarm is designed to activate via a separate float switch. Available in single and twin discharge configuration.

MODELS

- SumpFlo Twin (301)
- SumpFlo Twin (303)

TECHNICAL DATA

MODEL	301	303
Power Supply	230V AC	230V AC
Rated Current	1.9A	4.9A
Motor Rating	180W	500W
Frequency	50Hz	50Hz
Revs Per Minute	2720rpm	2800rpm
Max. Vert. Output	7m	12m
Max. Horiz. Output	50m	100m
Max. Flow Rate	168l/m	240l/m
Max. Liquid Temp.	<40°C	<40°C
Discharge Size	32mm	32mm
Cable Length	5m	5m
Weight	20kg	21kg
Colour	Yellow	Yellow

PUMP CURVE

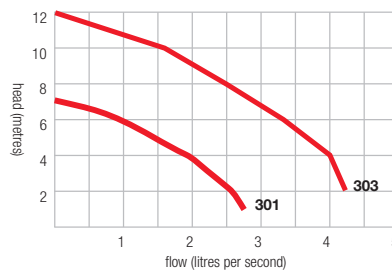

DIMENSIONS

MODEL	SUMPFLO TWIN
Height / Diameter (mm)	600 x 600
Clear opening (mm)	350 x 350

KEY FEATURES

- Easy to install
- Odour tight locking access cover
- Variable inlet positions
- Integral non-return valve preventing back flow
- Durable polyethylene tank
- Pre-moulded flotation points preventing movement below ground
- Integral step for dual pump setup
- Powerful submersible pumps

Visit www.wykamol.com for full technical drawings

ACCESSORIES



High level alarm (mains)

High level alarm (mains & battery)

Basement monitoring system

110mm rubber seal inlet

50mm rubber seal inlet

Inlay access cover

Battery back-up

Telemetric system

SUMPFLO BBPS



Single discharge option

Twin discharge option

The SumpFlo BBPS™ is specially designed for the removal of groundwater from basement cavity drainage membrane systems. The system comprises of a polyethylene tank, locking access cover (pedestrian duty, not suitable for roadways), powerful submersible pump and 24V backup pump. The system is very versatile, enabling the installer to locate inlets to their specifications.

The system comes complete with a battery back-up pump system, which is designed especially for where the possibility of primary pump failure through either a pump fault or loss of mains power would be catastrophic. The system acts as a back-up that will alert the end user if the water rises above the normal operating level within the tank and will activate a 24V back-up pump. Available in single and twin discharge configuration.

MODELS

- SumpFlo BBPS (301)
- SumpFlo BBPS (303)

TECHNICAL DATA

MODEL	301	303
Power Supply	230V AC	230V AC
Rated Current	1.9A	4.9A
Motor Rating	180W	500W
Frequency	50Hz	50Hz
Revs Per Minute	2720rpm	2800rpm
Max. Vert. Output	7m	12m
Max. Horiz. Output	50m	100m
Max. Flow Rate	168l/m	240l/m
Max. Liquid Temp.	<40°C	<40°C
Discharge Size	32mm	32mm
Cable Length	5m	5m
Weight	27kg	27.5kg
Colour	Yellow	Yellow

PUMP CURVE

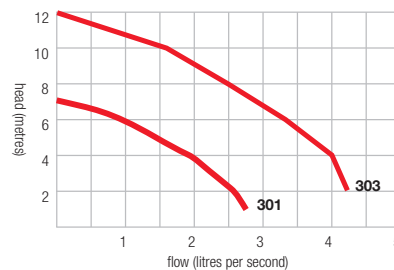

DIMENSIONS

MODEL	SUMPFLO BBPS
Height / Diameter (mm)	600 x 600
Clear opening (mm)	350 x 350

KEY FEATURES

- Easy to install
- Odour tight locking access cover
- Variable inlet positions
- Integral non-return valve preventing back flow
- Durable polyethylene tank
- Pre-moulded flotation points preventing movement below ground
- Integral step for dual pump setup
- Powerful submersible pumps

Visit www.wykamol.com for full technical drawings

ACCESSORIES

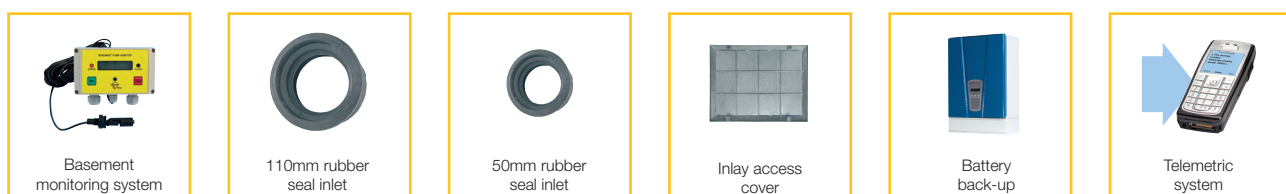

Basement monitoring system

110mm rubber seal inlet

50mm rubber seal inlet

Inlay access cover

Battery back-up

Telemetric system

SUMPFLO TWIN BBPS



Twin discharge standard

The SumpFlo Twin BBPS™ is specially designed for the removal of groundwater from basement cavity drainage membrane systems. The system comprises of a polyethylene tank, locking access cover (pedestrian duty, not suitable for roadways), 2no. powerful submersible pumps and 24V backup pump. The system is very versatile, enabling the installer to locate inlets to their specifications.

The system comes complete with a battery back-up pump system, which is designed especially for where the possibility of primary/secondary pump failure through either a pump fault or loss of mains power would be catastrophic. The system acts as a back-up that will alert the end user if the water rises above the normal operating level within the tank and will activate a 24V back-up pump. Comes standard with twin discharge.

MODELS

- SumpFlo Twin BBPS (301)
- SumpFlo Twin BBPS (303)

TECHNICAL DATA

MODEL	301	303
Power Supply	230V AC	230V AC
Rated Current	1.9A	4.9A
Motor Rating	180W	500W
Frequency	50Hz	50Hz
Revs Per Minute	2720rpm	2800rpm
Max. Vert. Output	7m	12m
Max. Horiz. Output	50m	100m
Max. Flow Rate	168l/m	240l/m
Max. Liquid Temp.	<40°C	<40°C
Discharge Size	32mm	32mm
Cable Length	5m	5m
Weight	34kg	35kg
Colour	Yellow	Yellow

PUMP CURVE

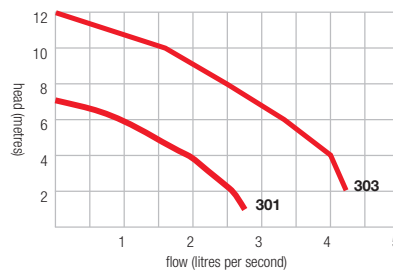

DIMENSIONS

MODEL	SUMPFLO TWIN BBPS
Height / Diameter (mm)	600 x 600
Clear opening (mm)	350 x 350

KEY FEATURES

- Easy to install
- Odour tight locking access cover
- Variable inlet positions
- Integral non-return valve preventing back flow
- Durable polyethylene tank
- Pre-moulded flotation points preventing movement below ground
- Integral step for dual pump setup
- Powerful submersible pumps

Visit www.wykamol.com for full technical drawings

ACCESSORIES

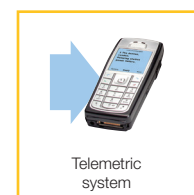
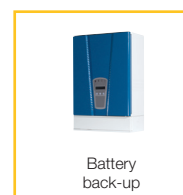
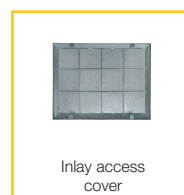
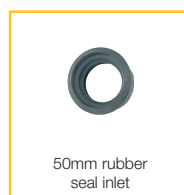

BLACKSUMP



The BlackSump™ is especially designed for the removal of groundwater from basement membrane systems. The system comprises of a polypropylene tank, circular locking access cover (pedestrian duty, not suitable for roadways) and a powerful submersible pump. The system is very versatile, enabling the installer to locate inlets to their specifications.

The system comes complete with a High Level Alarm (9V), which acts as a warning system to alert the end user if the water rises above the normal operating level within the tank. The alarm is designed to activate via a separate float switch.

MODELS

- Black Sump (301)

TECHNICAL DATA

MODEL	BLACK SUMP
Power Supply	230V AC
Rated Current	1.9A
Motor Rating	180W
Frequency	50Hz
Revolutions Per Min.	2720rpm
Max Vertical Output	7m
Max Horizontal Output	50m
Max Flow Rate	168l/m
Max Liquid Temp.	<40°C
Discharge Size	32mm
Cable Length	5m
Weight	11kg
Colour	Black

PUMP CURVE

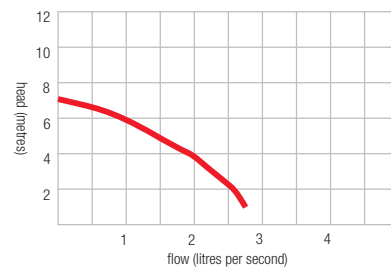

DIMENSIONS

MODEL	BLACK SUMP
Height / Diameter (mm)	450 x 550
Clear opening (mm)	450Ø

KEY FEATURES

- Easy to install
- Variable inlet positions
- Integral non-return valve preventing back flow
- Durable polyethylene tank
- Powerful submersible pump

Visit www.wykamol.com for full technical drawings

ACCESSORIES



High level alarm (mains)

High level alarm (mains & battery)

Basement monitoring system

110mm rubber seal inlet

50mm rubber seal inlet

Battery back-up

Telemetric system

SUMPFLO PRO



The Sumpflo Pro™ is specially designed for the removal of groundwater from basement cavity drainage membrane systems. The system comprises of a (large capacity) 200 litre polyethylene tank, locking access cover (pedestrian duty, not suitable for roadways) and a powerful submersible pump. The system is a very versatile, enabling the installer to locate inlets to their specifications.

MODELS

- SumpFlo Pro (303)

TECHNICAL DATA

MODEL	SUMPFLO PRO
Power Supply	230V AC
Rated Current	4.9A
Motor Rating	500W
Frequency	50Hz
Revolutions Per Min.	2800rpm
Max Vertical Output	12m
Max Horizontal Output	100m
Max Flow Rate	240l/m
Max Liquid Temp.	<40°C
Discharge Size	1¼"
Cable Length	5m
Weight	25kg
Colour	White

PUMP CURVE

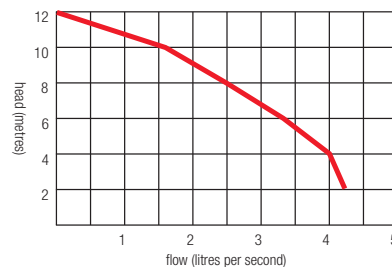

DIMENSIONS

MODEL	SUMPFLO PRO
Height / Diameter (mm)	1000 x 750
Clear opening (mm)	450 x 450

KEY FEATURES

- Easy to install
- Odour tight locking access cover
- Variable inlet positions
- Increased storage capacity
- Integral non-return valve preventing back flow
- Durable polyethylene tank
- Pre-moulded flotation points preventing movement below ground
- Integral step for dual pump setup
- Powerful submersible pump

Visit www.wykamol.com for full technical drawings

ACCESSORIES

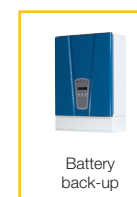

SUMPFLO PRO TWIN



The Sumpflo Pro Twin™ is specially designed for the removal of groundwater from basement cavity drainage membrane systems. The system comprises of a (large capacity) 200 litre polyethylene tank, locking access cover (pedestrian duty, not suitable for roadways) and two powerful submersible pumps. The system is a very versatile, enabling the installer to locate inlets to their specifications.

MODELS

- SumpFlo Pro Twin (303)

TECHNICAL DATA

MODEL	SUMPFLO PRO TWIN
Power Supply	230V AC
Rated Current	4.9A
Motor Rating	500W
Frequency	50Hz
Revolutions Per Min.	2800rpm
Max Vertical Output	12m
Max Horizontal Output	100m
Max Flow Rate	240l/m
Max Liquid Temp.	<40°C
Discharge Size	1¼"
Cable Length	5m
Weight	31.5kg
Colour	White

PUMP CURVE

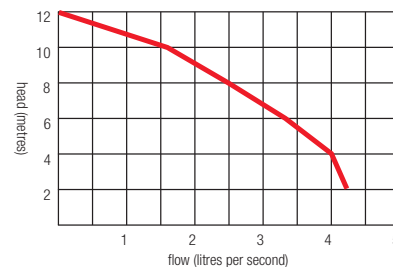

DIMENSIONS

MODEL	SUMPFLO PRO TWIN
Height / Diameter (mm)	1000 x 750
Clear opening (mm)	450 x 450

KEY FEATURES

- Easy to install
- Odour tight locking access cover
- Variable inlet positions
- Increased storage capacity
- Integral non-return valve preventing back flow
- Durable polyethylene tank
- Pre-moulded flotation points preventing movement below ground
- Integral step for dual pump setup
- Powerful submersible pumps

Visit www.wykamol.com for full technical drawings

ACCESSORIES





Foul water systems

Our range of foul water systems are specifically designed for the collection and removal of foul water where conventional gravity drainage to the main sewer is not possible and/or economical to install.

Our range comes in both single and twin pump configurations and in a variety of tank sizes. There is also a wide range of pumps/control options available to suit your precise requirements.



ONE-YEAR GUARANTEE
Terms and conditions apply.



SERVICING
See page 26.

For additional information and prices visit

www.wykamol.com



t: +44 (0)845 400 6666 f: +44 (0)845 400 3333 salesdepartment@wykamol.com

DRAINFLO 150



The DrainFlo 150 is a fully automatic packaged pumping station specifically designed for pumping foul water to high level when gravity drainage is not possible to install.

The system comprises of a polyethylene tank, locking access cover (pedestrian duty, not suitable for roadways) and a powerful submersible pump. The system is very versatile, enabling the installer to locate inlets to their specifications.

MODELS

- DrainFlo 150



TECHNICAL DATA

Model	DrainFlo150
Power Supply	230V AC
Rated Current	1.9A
Motor Rating	250W
Frequency	50Hz
Revolutions Per Min.	3000rpm
Max Vertical Output	8m
Max Horizontal Output	70m
Max Flow Rate	180l/m
Max Liquid Temp.	<40°C
Discharge Size	50mm OD
Cable Length	10m
Weight	40Kg
Colour	White

PUMP CURVE

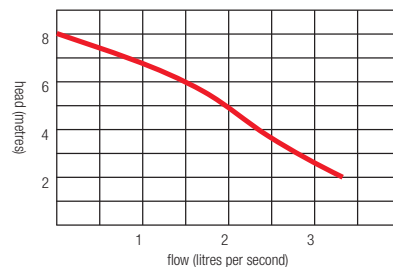

DIMENSIONS

MODEL	DRAINFLO 150
Length / Width / Height (mm)	700 x 550 x 550
Clear opening (mm)	600 x 450

KEY FEATURES

- Large storage capacity
- Hidden due to below ground installation
- Silent operation
- Powerful pump for longer lifespan, higher flow rates and pumping distance

Visit www.wykamol.com for full technical drawings

ACCESSORIES



DRAINFLO 200



The DrainFlo 200 is a fully automatic packaged pumping station specifically designed for pumping foul water to high level when gravity drainage is not possible to install.

The system comprises of a polyethylene tank, locking access cover (pedestrian duty, not suitable for roadways) and a powerful submersible pump. The system is very versatile, enabling the installer to locate inlets to their specifications.

MODELS

- DrainFlo 200



TECHNICAL DATA

MODEL	DRAINFLO 200
Power Supply	230V AC
Rated Current	5.1A
Motor Rating	750W
Frequency	50Hz
Revolutions Per Min.	2850rpm
Max Vertical Output	14m
Max Horizontal Output	150m
Max Flow Rate	400l/m
Max Liquid Temp.	<40°C
Discharge Size	63mm OD
Cable Length	10m
Weight	65Kg
Colour	White

PUMP CURVE

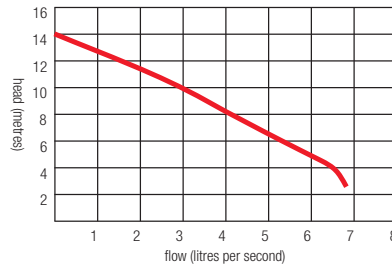

DIMENSIONS

MODEL	DRAINFLO 200
Height / Diameter (mm)	1000 x 750
Clear opening (mm)	450 x 450

KEY FEATURES

- Large storage capacity
- Hidden due to below ground installation
- Silent operation
- Powerful pump for longer lifespan, higher flow rates and pumping distance

Visit www.wykamol.com for full technical drawings

ACCESSORIES

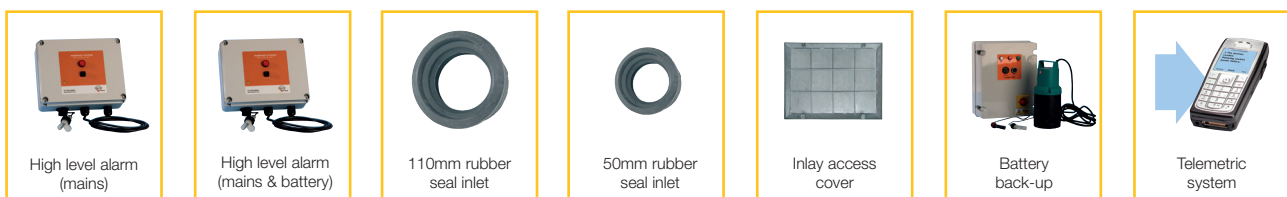

DRAINFLO 360



The DrainFlo 360 is a fully automatic packaged pumping station specifically designed for pumping foul water to high level when gravity drainage is not possible to install.

The system comprises of a polyethylene tank, locking access cover (pedestrian duty, not suitable for roadways), powerful submersible pump and control panel. The system is very versatile, enabling the installer to locate inlets to their specifications.

MODELS

- DrainFlo 360



TECHNICAL DATA

MODEL	DRAINFLO 360
Power Supply	230V AC
Rated Current	5.1A
Motor Rating	750W
Frequency	50Hz
Revolutions Per Min.	2850rpm
Max Vertical Output	14m
Max Horizontal Output	150m
Max Flow Rate	400l/m
Max Liquid Temp.	<40°C
Discharge Size	63mm OD
Cable Length	10m
Weight	95Kg
Colour	White

PUMP CURVE

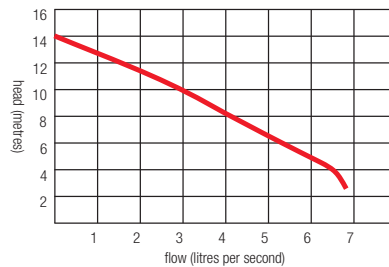

DIMENSIONS

MODEL	DRAINFLO 360
Height / Diameter (mm)	1250 x 850
Clear opening (mm)	600 x 450

KEY FEATURES

- Large storage capacity
- Hidden due to below ground installation
- Silent operation
- Powerful pump for longer lifespan, higher flow rates and pumping distance

Visit www.wykamol.com for full technical drawings

ACCESSORIES

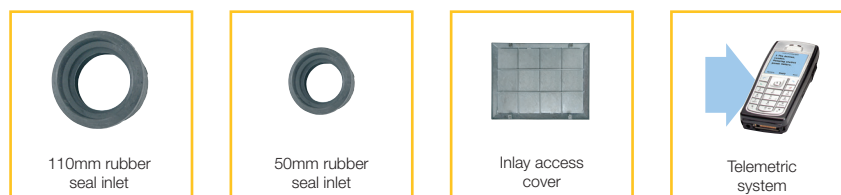

DRAINFLO 360 TWIN



The DrainFlo 360 Twin is a fully automatic packaged pumping station specifically designed for pumping foul water to high level when gravity drainage is not possible to install.

The system comprises of a polyethylene tank, locking access cover (pedestrian duty, not suitable for roadways), two powerful submersible pumps and control panel. The system is very versatile, enabling the installer to locate inlets to their specifications.

MODELS

- DrainFlo 360 Twin



TECHNICAL DATA

MODEL	DRAINFLO 360 TWIN
Power Supply	230V AC
Rated Current	5.1A (per pump)
Motor Rating	750W
Frequency	50Hz
Revolutions Per Min.	2850rpm
Max Vertical Output	14m
Max Horizontal Output	150m
Max Flow Rate	400l/m
Max Liquid Temp.	<40°C
Discharge Size	63mm OD
Cable Length	10m
Weight	135Kg
Colour	White

PUMP CURVE

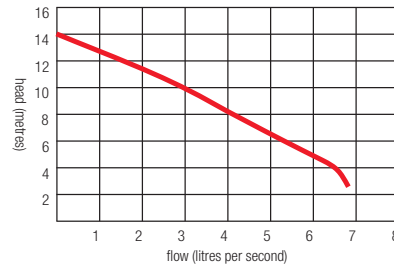

DIMENSIONS

MODEL	DRAINFLO 360 TWIN
Height / Diameter (mm)	1250 x 850
Clear opening (mm)	600 x 450

KEY FEATURES

- Large storage capacity
- Hidden due to below ground installation
- Silent operation
- Powerful pump for longer lifespan, higher flow rates and pumping distance

Visit www.wykamol.com for full technical drawings

ACCESSORIES





Above ground systems

Our range of macerators and waste water pump systems are specifically designed for the removal of waste water from where conventional gravity drainage to the main sewer is not possible and/or economical to install.

There are a variety of different models to suit most installations. These pumping systems can be installed in a variety of applications from light domestic through to industrial.



ONE-YEAR GUARANTEE
Terms and conditions apply.



SERVICING
See page 26.

For additional information and prices visit
www.wykamol.com



t: +44 (0)845 400 6666 f: +44 (0)845 400 3333 salesdepartment@wykamol.com

POWERFLUSH



The PowerFlush is a fully automatic macerator suitable for pumping waste water from a complete bathroom to a higher level when gravity drainage is not possible and/or economical to install.

The system is suitable for installing either at the initial building stage or retro fitting to existing buildings and can accept waste connections from a toilet, basin, shower or bidet.

MODELS

- PowerFlush



TECHNICAL DATA

MODEL	POWERFLUSH
Power Supply	230V AC
Rated Current	4.7A
Motor Rating	1100W
Frequency	50Hz
Revolutions Per Minute	2900rpm
Max. Vertical Output	7m
Max. Horizontal Output	50m
Max. Flow Rate	96l/m
Max. Liquid Temperature	<60°C intermittent
Discharge Size	32mm
Cable Length	2m
Weight	9kg
Colour	White

PUMP CURVE

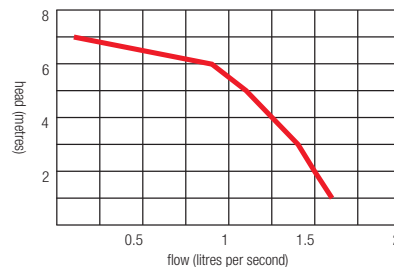

DIMENSIONS

MODEL	POWERFLUSH
Height / Width / Length (mm)	414 x 197 x 287

KEY FEATURES

- Fully automatic
- Heavy duty macerator
- Complete bathroom pump
- Compact
- Easy to install

Visit www.wykamol.com for full technical drawings

AQUAFLUSH



The AquaFlush is a fully automatic waste water pumping system suitable for pumping waste water to a higher level when gravity drainage is not possible and/or economical to install.

The system is suitable for installing either at the initial building stage or retro fitting to existing buildings and can accept waste connections from a sink, washing machine, dishwasher or similar.

MODELS

- AquaFlush

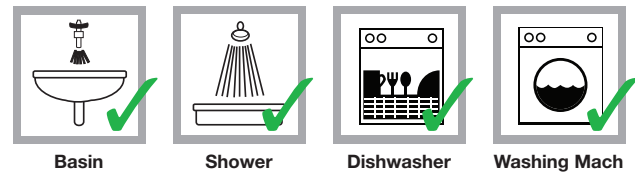

TECHNICAL DATA

MODEL	AQUAFLUSH
Power Supply	230V AC
Rated Current	2.1A
Motor Rating	460W
Frequency	50Hz
Revolutions Per Minute	2900rpm
Max. Vertical Output	6m
Max. Horizontal Output	45m
Max. Flow Rate	180l/m
Max. Liquid Temperature	<60°C intermittent
Discharge Size	32mm
Cable Length	3m
Weight	5.3kg
Colour	White

PUMP CURVE

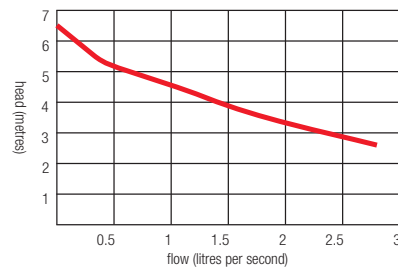

DIMENSIONS

MODEL	AQUAFLUSH
Height / Width / Length (mm)	345 x 400 x 390

KEY FEATURES

- Fully automatic
- Waste water pumping system
- Suitable for utility room
- Odour-tight tank
- Easy to install

Visit www.wykamol.com for full technical drawings

ACCESSORIES





High level alarms

High level alarms range provides an early warning in case of a high level condition.



ONE-YEAR GUARANTEE
Terms and conditions apply.



SERVICING
See page 26.

For additional information and prices visit
www.wykamol.com



t: +44 (0)845 400 6666 f: +44 (0)845 400 3333 salesdepartment@wykamol.com

HIGH LEVEL ALARM 9V



A 9V battery powered high level alarm suitable for installation within any of the ground water pump systems. Audio sounder with mute button.

KEY FEATURES

- No mains supply required
- Easy to install
- Can be retrofitted

SUITABLE FOR

- SumpFlo (as standard)
- SumpFlo Twin (as standard)
- SumpFlo BBPS
- SumpFlo Twin BBPS
- BlackSump (as standard)

DIMENSIONS

MODEL	HIGH LEVEL ALARM 9V
Height / Width / Length (mm)	90 / 90 / 30

HIGH LEVEL ALARM (MAINS OPERATED)



MODELS

- Microswitch float switch (suitable for ground water)
- Sewage float switch (suitable for foul water)

KEY FEATURES

- Visual lamp
- Loud 24V sounder
- Mute button
- Mechanical float switch

SUITABLE FOR

- SumpFlo
- SumpFlo Twin
- Sump Flo Pro
- Sump Flo Pro Twin
- DrainFlo 150
- DrainFlo 200

DIMENSIONS

MODEL	HLA (MAINS)
Height / Width / Length (mm)	150 / 190 / 80

This unit should be wall mounted and will notify clients of a high water level via an audio and visual signal.

The unit can be supplied with either a microswitch float switch suitable for ground water systems, or a sewage float switch suitable for foul water systems.

HIGH LEVEL ALARM (MAINS & BATTERY OPERATED)



MODELS

- Microswitch float switch (suitable for ground water)
- Sewage float switch (suitable for foul water)

KEY FEATURES

- Visual lamp
- Loud 24V sounder
- Mute button
- Mechanical float switch

SUITABLE FOR

- SumpFlo
- SumpFlo Twin
- Sump Flo Pro
- Sump Flo Pro Twin
- DrainFlo 150
- DrainFlo 200

Should there be a power failure the trickle charge battery will automatically take over. This unit should be wall mounted and will notify clients of a high water level via an audio and visual signal. The unit can be supplied with either a microswitch float switch suitable for ground water systems, or a sewage float switch suitable for foul water systems.

DIMENSIONS

MODEL	HIGH LEVEL ALARM 9V
Height / Width / Length (mm)	200 / 250 / 90

BASEMENT MONITORING SYSTEMS & BATTERY BACK UP



KEY FEATURES

- Compact
- Multi-function
- Remote notification

SUITABLE FOR

- SumpFlo
- SumpFlo Twin
- SumpFlo BBPS
- SumpFlo Twin BBPS
- Sump Flo Pro
- Sump Flo Pro Twin

Designed to monitor automatic water sump pumps, it is wired in the power line to the pump. It also has the option to add a high level water alarm indicator. A built-in alarm relay can signal a home automation system, house alarm or a remote dialler.

DIMENSIONS

MODEL	BMS-BB
Height / Width / Length (mm)	90 / 158 / 60



Battery back-up systems

Battery back-up systems provide peace of mind by monitoring the pump system and activating the battery operated pump/s in the event of mains power loss.



ONE-YEAR GUARANTEE
Terms and conditions apply.



SERVICING
See page 26.

For additional information and prices visit
www.wykamol.com



t: +44 (0)845 400 6666 f: +44 (0)845 400 3333 salesdepartment@wykamol.com

POWERSAFE

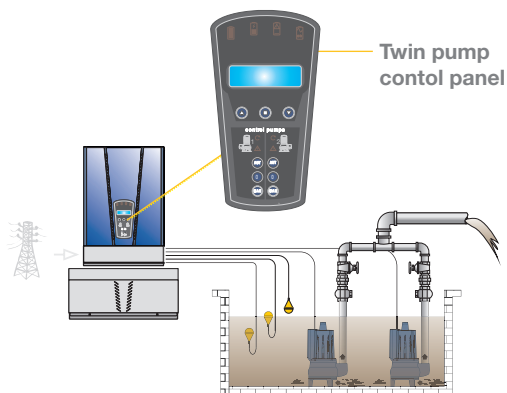

Available in single or twin pump configurations

The PowerSafe® stores power in case of a mains power loss, protecting your property from flooding. Don't worry, the PowerSafe® is completely automatic!

The PowerSafe range of fully automatic battery back up systems are designed to offer your customer peace of mind for their basement drainage. The system can be used on single or dual pump configurations and is suitable for both groundwater and foul waste. It comes complete with a built in GSM telemetry for complete monitoring of your pumped drainage system (not available on the PowerSafe ECO).

The PowerSafe is suitable for installing either at the initial building stage, or retrofitting to existing buildings. The system comprises of a PowerSafe control panel, cable cover, battery holder and batteries (no. of batteries to be specified at time of order).

SUITABLE FOR

- All pumping stations (below and above ground)

KEY FEATURES

- Hand/Off/Auto switches
- High Level Audible Alarm with Mute Button
- Duty/Assist Configuration (Alternates switching of pumps)
- Visual Indication for: (Supply On, Pumps Running, Pumps Tripped & HL)
- Available in both single & dual pump configuration.
- Single-phase power supply 230V
- Automatic battery charger
- LCD backlit display*
- Hour run meter*
- No. Start meter*

- Overload protection
- Reporting of scheduled maintenance*
- Automatic load TEST*
- General alarm output
- Removable front door
- Steel box painted with powder, protection IP31
- Integral telemetric GSM module*

* Not available on PowerSafe ECO.

† PowerSafe ECO: The battery is included in the control panel. For dimensions consider only the control panel.

DIMENSIONS †

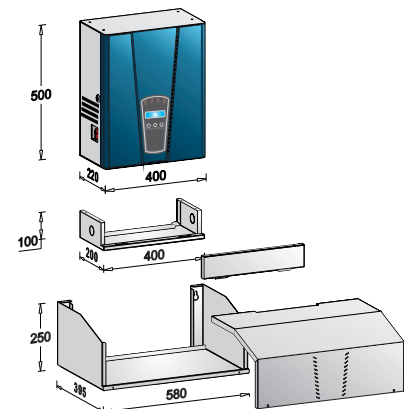

UPS 750



This battery back-up system, has been designed for ease of use and works simply by wiring the mains pump into the server unit, in the event of a power failure the main unit's heavy duty battery will keep the pumps going for a long period of time. This system is quick and easy to install.

TECHNICAL DATA

MODEL	UPS 750
Power Supply to UPS	230V AC
Output Power Capacity	600W
Frequency	50Hz
Battery Type	Maintenance-free lead acid
Expected Battery Life	3-5 years
Recharge Time	3 hours
Backup Time	340Watts = 45mins
Weight	24kg

DIMENSIONS

MODEL	UPS 750
Height / Width / Length (mm)	432 / 89 / 490

SUITABLE FOR

- SumpFlo
- SumpFlo Twin

POWERFLO

PUMP CURVE

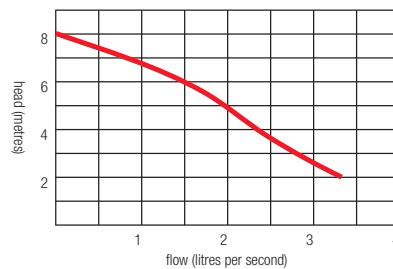

The battery back-up system is designed especially for where the possibility of primary pump failure through either a pump fault or loss of mains power would be catastrophic. The system comprises of a control panel, 24V back-up pump, 3 no. float switches and a non-return valve.

TECHNICAL DATA

MODEL	POWERFLO
Power Supply to Panel	230V AC
Power Supply to Pump	24V
Frequency	50Hz
Motor Rating	Intermittent
Max. Flow Rate	180l/min
Max. Vertical Output	6.5m
Max. Horizontal Output	45m
Max. Liquid Temp.	<40°C
Rated Current	13amps
Discharge Size	1¼"
Cable Length	4m
Battery Life	45min
Colour	Grey

DIMENSIONS

MODEL	POWERFLO
Height / Width / Length (mm)	380 / 300 / 180

SUITABLE FOR

- SumpFlo
- SumpFlo Twin
- SumpFlo Pro
- SumpFlo Pro Twin

Aftersales



PLANNED SERVICING

Our ISO9001 planned servicing:

- Increases the life expectancy of your equipment
- Reduces running costs including energy and maintenance
- Reduces the risk of breakdowns with their resultant problems this causes

Planned servicing is available for all our customers' pumps and Pump Packages.

We will:

- Service your equipment on a regular basis
- Provide full reporting on the works carried out, the condition of the equipment
- Make recommendations to replace spares or parts that may be required
- Arrange service visits to suit you
- Reduce our hourly charges for unscheduled callouts
- Use fully trained service engineers
- Provide high-priority scheduling for emergency call outs

EMERGENCY CALL-OUTS

In the event of a system failure we understand the need for urgency. All emergency call-outs are treated as a priority and we aim to provide a rapid response. With nationwide coverage and service vehicles located throughout the United Kingdom we aim to attend site within 24 hours from initial receipt of your call.

Our service coordinators will identify, where possible, your specific equipment and our engineers will aim to attend site with any spare parts that may be required. In the unlikely event that the repairs cannot be made on the initial visit, we are able to provide temporary replacements while the relevant parts are ordered / repaired from our service centre. Should more complex repairs be required these are undertaken at our service centre by our fully trained service engineers using only genuine manufacturer's parts.

Throughout all repairs your service coordinator will keep you informed of the ongoing progress with regular updates.

COMMISSIONING

Once the civil works have been completed our service department can arrange for your system to be commissioned. Our commissioning service comprises of our engineers attending site and installing the pumps with all associated equipment.

Our engineers will ensure that the system is operating in accordance with our installation & operating guidelines and you will be provided with a signed commissioning certificate along with the O&M manual upon completion.

Our commissioning service provides you with peace of mind knowing that the system is installed correctly in turn ensuring that you comply with our warranty conditions.

Supplied in conjunction with Edincare Pumps



SITE SPECIFICATION FORM

In order for Wykamol to specify the correct pumping station for your particular application we require specific details of the pumping duty. Please photocopy and complete the form, then fax to 0845 400 3333.

CUSTOMER / SITE DETAILS

Name	
Company	
Address	
Postcode	
Telephone	
Fax	

Date		/		/	
Site contact					
Address					
Postcode					
Telephone					

Application

FOUL / WASTE WATER

Appliance	No. of	l/s
W.C.		x 0.119
Wash Basin		x 0.38
Bath		x 0.38
Shower		x 0.19
Bidet		x 0.19
Urinal		x 0.19
Utility Sink		x 0.84
Dishwasher		x 0.25
Wash. Machine		x 0.7

Occupants		persons
Inlet Depth (A)		mm
Vertical Lift (B)		mm
Horizontal Run (C)		mm
Inlet Size		mm
Power	240v / 415v	
Distance to Panel		m

SURFACE WATER

Surface type	m ²
Roof	
Paved Yard	
Footway	
Carriageway	
Garden Land	

Inlet Depth (A)		mm
Vertical Lift (B)		mm
Horizontal Run (C)		mm
Inlet Size		mm
Power	240v / 415v	
Distance to Panel		m

TYPICAL INSTALLATION

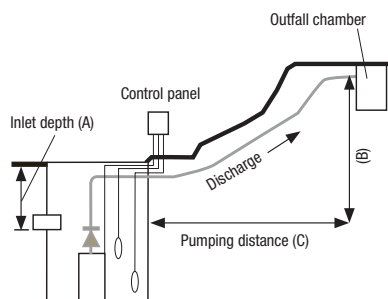

NOTE - All applications that involve pumping downhill and/or surface water, must be highlighted at the earliest possible moment.

OFFICE USE

Product specified

Specifier's name

Date / /

**8 GOOD
REASONS
TO CHOOSE
WYKAMOL**

DAMP PROOFING

TIMBER TREATMENTS

**STRUCTURAL
WATERPROOFING**

THOR HELICAL

ANTI-CONDENSATION

SURFACE TREATMENTS

TRAINING

GUARANTEES



Wykamol Group

Unit 3, Boran Court, Network 65 Business Park, Hapton,
Burnley, Lancashire BB11 5TH

t: +44 (0)845 400 6666 f: +44 (0)845 400 3333

www.Wykamol.com e: salesdepartment@Wykamol.com

