

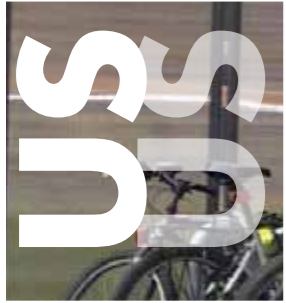

ABOUT US



Cyclepods Ltd launched in 2005 to transform and revolutionise cycle storage! Year on year since inception Cyclepods Ltd have developed, designed and manufactured new innovative cycle storage solutions.

We believe that cycle storage doesn't need to be ugly! We are the only cycle storage company which is Carbon Neutral providing a range of stylish solutions, all of which are manufactured in the UK from either 100% recycled or recyclable material!

Available in a wide range of different colours and finishes, our products lend themselves to different environments; bike parking no longer has to be hidden as an eyesore. In fact, we have gone a stage further and provided advertising and branding opportunities on our products. We believe that the use of recycled materials should not compromise quality and that bike parking should encourage cycling and a healthier way of life. Our unique designs hold and protect each bike discretely.

Unlike traditional bike racks, our products prevent overcrowding and damage to the bikes, making us very bike and cyclist friendly!

Cyclepods Ltd are ISO9001 and members of The Royal Society for the Prevention of Accidents

At Cyclepods, we are proud of our environmental credentials and social responsibility. The entire Cyclepod range is made from either 90-100% recycled (and recyclable) aluminium, and 100% recycled (and recyclable) MDPE plastic.

Cyclepods Ltd is certified as a **Carbon Neutral company**. So what does this mean?

If a product, activity or company carries the Carbon Neutral® mark, it means that:

- 1; CO2 emissions have been measured
- 2; Reductions identified
- 3; Remaining emissions have been offset through high quality carbon projects around the world
- 4; Thought has been invested into branding and communication of climate change action.

Becoming a Carbon Neutral company is another step for Cyclepods in its mission to encourage cycling by providing Innovative, Space-saving, Secure and Sustainable Cycle storage to the world.



RAL 7035 Light Grey	RAL 6024 Pine Green	RAL 5017 Traffic Blue
-------------------------------	-------------------------------	---------------------------------

Other colours available at extra cost, speak to a member of our sales team for details.



WALL MOUNTED BIKE SHELTER

Product Name: Wall Mounted Bike Shelter

Product Description

The shelter frame is made from tubular steel sections supporting a twin-walled polycarbonate roof. Inside, there is a wall mounted colour co-ordinated twin-level bike rack designed to hold 8 (eight) bikes.

The racks accept most sizes of bike tyre including those from mountain bikes and allow the user to chain a wheel of the bike to the rack. Wall mounted cycle shelters are modular in design and come in widths measuring 3000mm wide and 1900mm deep. Long runs of cycle parking shelters can be created from initial and extension units positioned side to side.

The wall mounted cycle shelter must be installed by bolting the adjustable feet to 250mm thick concrete pads, or by embedding the legs in concrete below ground level. Installing directly into block paving or tarmac is not recommended.

- A choice of frame colours is available as standard with optional special colours available at extra cost.
- Robust all-weather construction
 - Comes complete with twin-level bike rack for storing up to eight bikes
 - All metal parts powder coated for improved weather resistance
 - Parabolts for front support legs included. Must be bolted to 250mm thick concrete (wall fixings not included)
 - Delivered in knock-down form with easy to follow instructions for onsite assembly and installation
- Delivery time: typically 14-21 working days.

INCLUDES FREE DELIVERY TO MAINLAND UK

Costs:

Wall Mounted Bike Shelter	£850 each
With bike rack	£999 each

Colour Options:
Pine Green, Light Grey, Traffic Blue

Price includes delivery. Price plus VAT. Prices correct at time of print subject to charge without prior notice..



PADSTOW CYCLE SHELTER

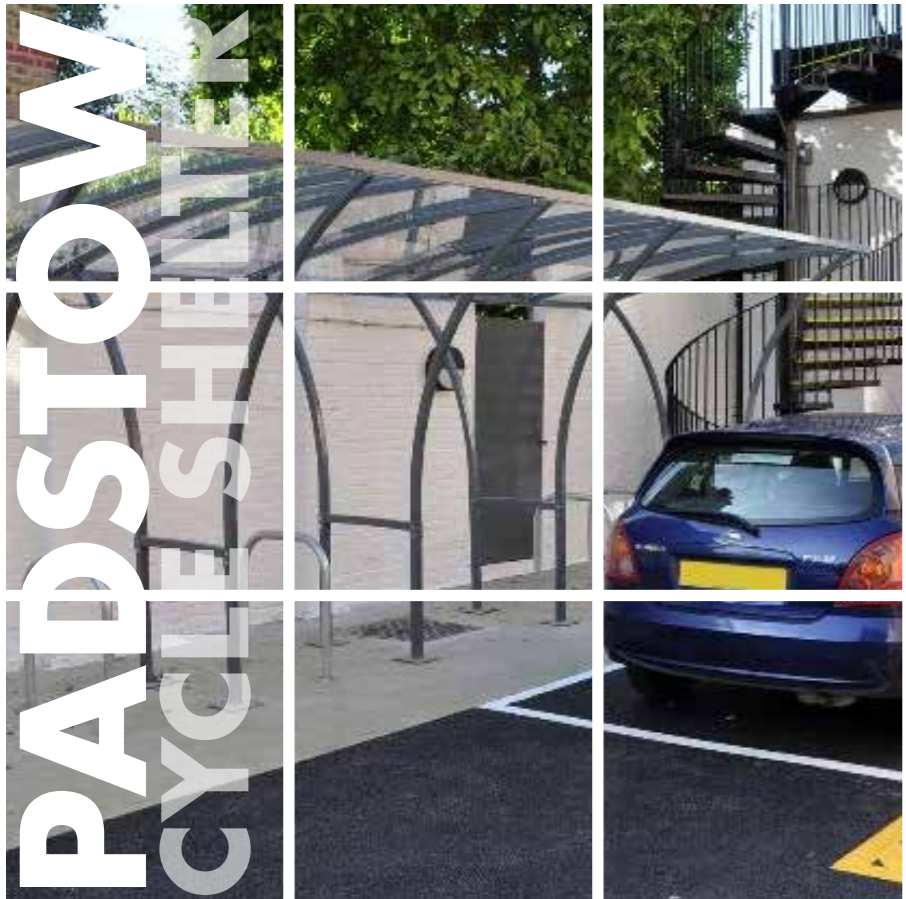

Product Name: Padstow Cycle Shelter

Product Description
 Galvanised or Zinc with Powder coated finish options
 Easily accessed from both sides
 Zinc coated with a powder coated finish in any RAL colour – also available fully galvanised
 Leg frames can either be bolted to the floor or grouted into the ground

Delivered in knock-down form with easy to follow instructions for on site assembly and installation available in in 2000, 3000,4000 and 5000mm width's
 Delivery time: typically 14-21 working days.

INCLUDES FREE DELIVERY TO MAINLAND UK

Note: if choosing powder coated, please let us know the colour is the note section when ordering. Colours are shown in gallery image

Additional Information
 Dimensions: 215 x 200 x 253 cm

Costs:
 Padstow Cycle Shelter (Galvanised) **£1,050 each**

Configuration:

2000mm Width	£1,050 each
3000mm Width	£1,190 each
4000mm Width	£1,330 each
5000mm Width	£1,470 each

Colour Options:
 Zinc and Power Coated **£1,075 each**

Price includes delivery. Price plus VAT. Prices correct at time of print subject to charge without prior notice..

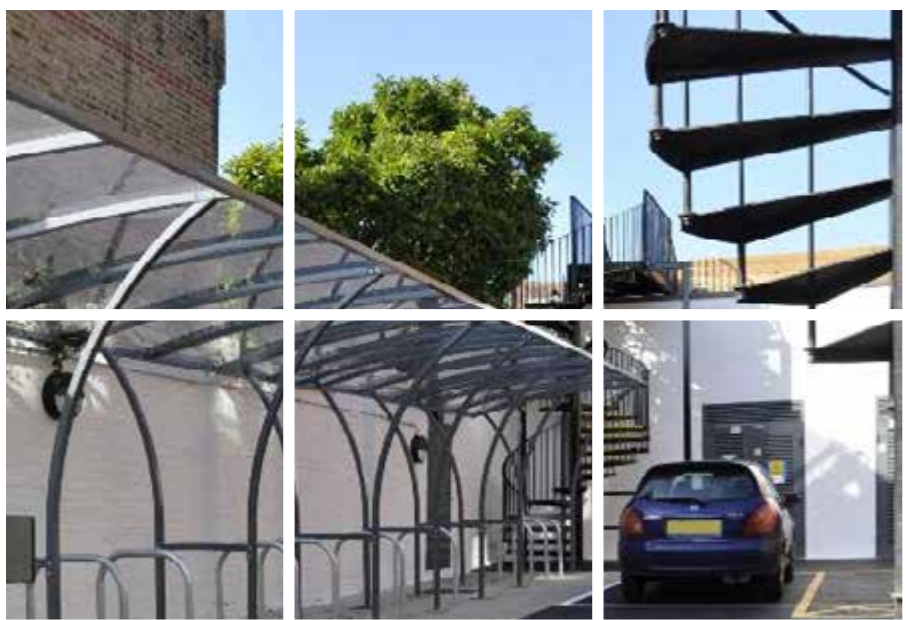

Product Name: Canterbury Bike Shelter

Product Description
 Bream and Code for Sustainable Homes Compliant
 This bike shelter can help contribute towards gaining ENE8 Cycle storage credits when used in the appropriate situation, under the Code for Sustainable Homes. Specification
 Shelter manufactured from hot dipped steel Galvanised 50 x 50 box section to BSEN ISO1461
 Transparent PET 4mm roof
 Optional Transparent PET 4mm sides
 Aluminium fixing straps
 All fixings to be galvanised or aluminium
 Nyloc nuts are used for safety
 Anti climb end panels
 No crawl under perimeters.
 Angled roof

Installation Notes
 Two ground fixing options-
 Base plate fixing
 Submerged fixing
 No Cycle racks provided

Additional Information
 Weight: 99kg
 Dimensions: 410 x 220 x 210 cm

Costs:
 Canterbury Bike Shelter **£1,100 each**

Shelter Finish Options:
 Standard Galvanised
 Powder Coated **£1,250 each**

Floor Fixing Options:
 Fixed Legs
 Adjustable Fixing Legs **£60 each**

Side Panel Options:
 Pair of side panels **£250 each**

Gate Options:
 Swing Gates **£400 each**
 Side Gates: **£650 each**

Extension Unit Option:
 1 x Extension Unit **£1,100 each**

Installation Options:
 Delivery only **+£175**
 Delivery and Installation without footings **+£650**
 Delivery and Installation with footings **+£795**

Price plus VAT.Prices correct at time of print subject to charge without prior notice.

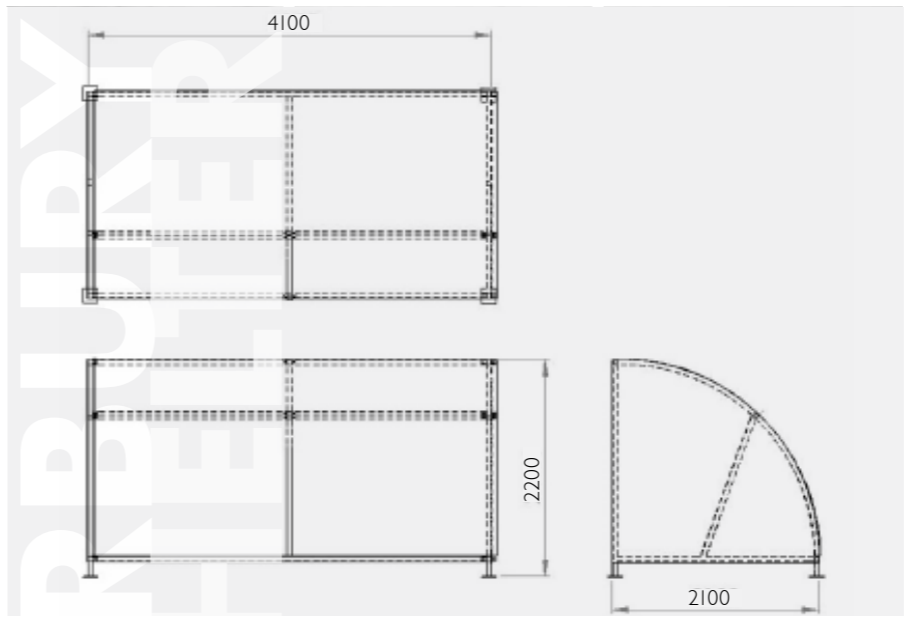



Product Name: Canterbury Compound 20 Bikes

Product Description

Breeam and Code for Sustainable Homes Compliant
This cycle compound can help contribute towards gaining ENE8 Cycle storage credits when used in the appropriate situation, under the Code for Sustainable Homes

Specification

- Shelter manufactured from hot dipped steel Galvanised 50 x 50 box section to BSEN ISO1461
- Transparent PET 4mm roof
- Optional Transparent PET 4mm sides
- Aluminium fixing straps
- All fixings to be galvanised or aluminium
- Nyloc nuts are used for safety
- anti climb end panels
- No crawl under perimeters.
- Angled roof
- Rear security panel
- Front security swinging gate
- Padlock/Hasp locking mechanism
- Will secure 20 bikes

Installation Notes

- Two ground fixing options
- Base plate fixing or Submerged fixing
- Free shipping does not apply to our shelter range.
- No Cycle racks provided

Additional Information

Dimensions: 520 x 410 x 220 cm

Costs:

Canterbury Compound 20 Bikes (Galvanised) **£3,600 each**

Shelter Finish:

Powder Coated **£3,850 each**

Floor Fixing:

Fixed Legs
Adjustable Fixing Legs **£150 each**

Installation Options

- Delivery only **+£250**
- Delivery and Install without footings **+£650**
- Delivery and install with footings **+£995**

Price plus VAT. Prices correct at time of print subject to charge without prior notice.

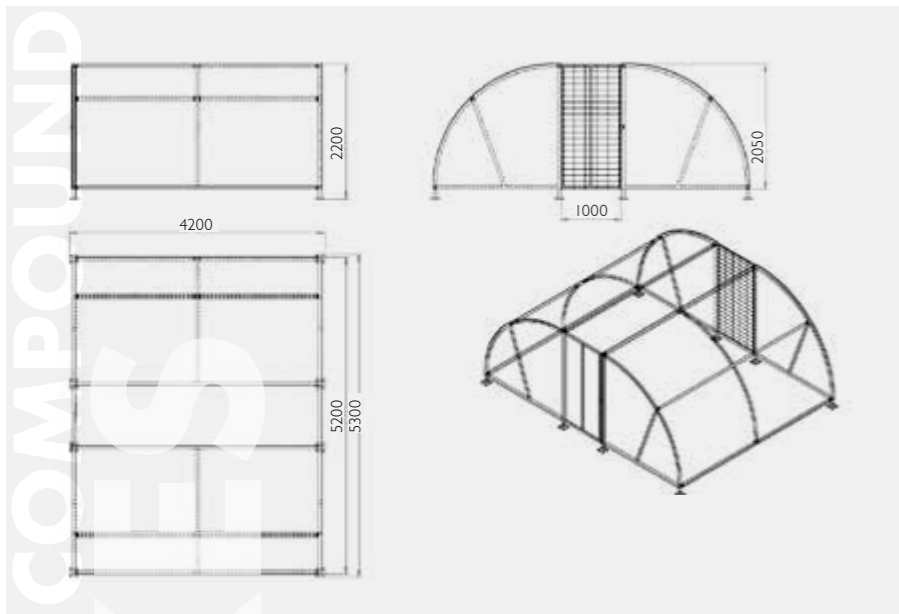

Product Name: Canterbury Compound 40 Bikes

Product Description

Breeam and Code for Sustainable Homes Compliant
This cycle compound can help contribute towards gaining ENE8 Cycle storage credits when used in the appropriate situation, under the Code for Sustainable Homes

Specification

- Shelter manufactured from hot dipped steel Galvanised 50 x 50 box section to BSEN ISO1461
- Transparent PET 4mm roof,
- Optional Transparent PET 4mm sides
- Aluminium fixing straps
- All fixings to be galvanised or aluminium
- Nyloc nuts are used for safety
- anti climb end panels
- No crawl under perimeters.
- Angled roof
- Rear security panel
- Front security swinging gate
- Padlock/Hasp locking mechanism
- Will secure 40 bikes

Installation Notes

- Two ground fixing options
- Base plate fixing or Submerged fixing
- Free shipping does not apply to our shelter range.
- No Cycle racks provided

Additional Information

Dimensions: 815 x 520 x 221cm

Costs:

Canterbury Compound 40 Bikes (Galvanised) **£5,850 each**

Shelter Finish:

Powder Coated **£6,250 each**

Floor Fixing:

Fixed Legs
Adjustable Fixing Legs **£250 each**

Installation Options

- Delivery only **+£450**
- Delivery and Install without footings **+£995**
- Delivery and install with footings **+£1,500**

Price plus VAT. Prices correct at time of print subject to charge without prior notice.

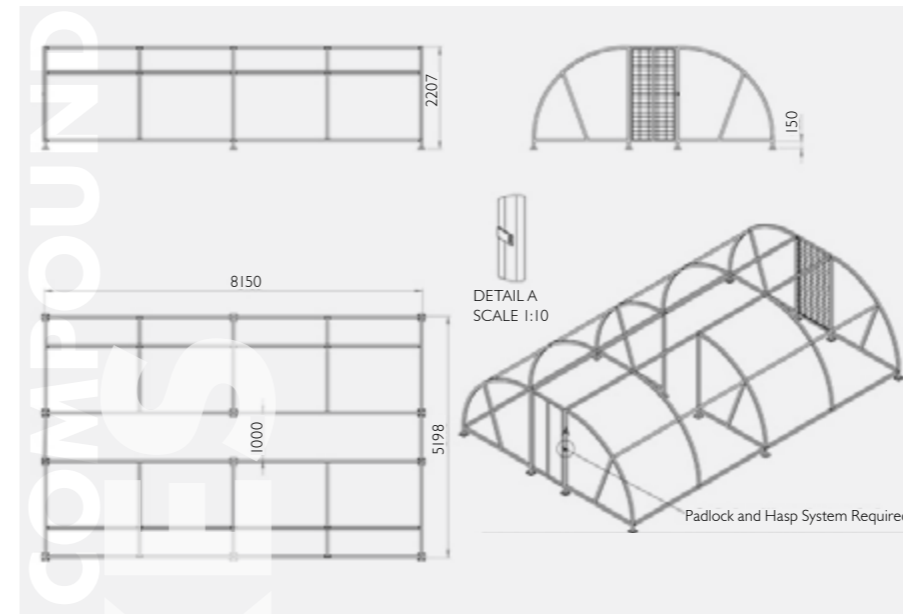

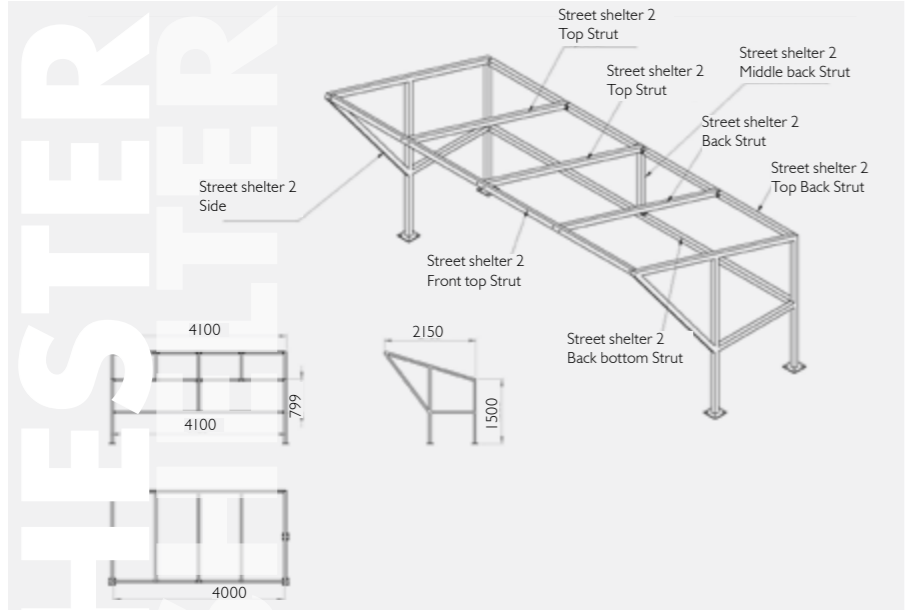

Product Name: Manchester Cycle Shelter

Product Description

Bream and Code for Sustainable Homes Compliant
This bike shelter can help contribute towards gaining ENE8 Cycle storage credits when used in the appropriate situation, under the Code for Sustainable Homes Specification

Two ground fixing options-
Base plate fixing
Submerged fixing

Free shipping does not apply to our shelter range.
No Cycle racks provided

Installation Notes

Two ground fixing options-
Base plate fixing
Submerged fixing
Free shipping does not apply to our shelter range.
No Cycle racks provided

Additional Information

Weight: 99kg
Dimensions: 410 x 220 x 215 cm

Costs:

Manchester Cycle Shelter **£1,300 each**

Shelter Finish Options:

Standard Galvanised **£1,450 each**
Powder Coated

Floor Fixing Options:

Fixed Legs **£60 each**
Adjustable Fixing Legs

Side Panel Options:

Pair of side panels **£200 each**

Extension Unit Option:

1 x Extension Unit **£1,300 each**

Installation Options:

Delivery only **+£175**
Delivery and Installation without footings **+£650**
Delivery and Installation with footings **+£795**

Price plus VAT. Prices correct at time of print subject to charge without prior notice.



Product Name: Exeter Bike Shelter

Product Description

Anodised aluminium tubular uprights 50mm diameter for assembly with cast aluminium connectors, locked in place with stainless steel screws.

Roof and cladding: 10mm translucent anti-UV cellular polycarbonate glazing panels on an anodised aluminium profile frame.

Bike rack pictured not included, fits high low rack perfectly

Designed to be directly concreted into the ground.

Can easily be extended.

Delivery time: typically 14-21 working days.

Additional Information

Dimensions: 257 x 197 x 215cm

INCLUDES FREE DELIVERY

Costs:

Exeter Bike Shelter **£1,300 each**

Price includes delivery, Price plus VAT.
Prices correct at time of print subject to charge without prior notice.





Product Name: London Bike Shelter

Product Description

Breem and Code for Sustainable Homes Compliant
This bike shelter can help contribute towards gaining ENE8 Cycle storage credits when used in the appropriate situation, under the Code for Sustainable Homes.

Specification

Shelter manufactured from hot dipped steel Galvanised 61 Dia hollow tube section to BSEN ISO1461
Transparent PET 4mm roof
Aluminium fixing straps
All fixings to be galvanised or aluminium
Nyloc nuts are used for safety
Angled roof

Installation Notes

Two ground fixing options
Base plate fixing
Submerged fixing
Free shipping does not apply to our shelter range. No Cycle racks provided.

Additional Information

Dimensions: 410 x 225 x 255 cm

Costs:

London Bike Shelter **£1,700 each**

Shelter Finish Options:

Standard Galvanised **£1,850 each**

Powder Coated **£1,850 each**

Extension Unit Option:

1 x Extension Unit **£1,600 each**

Installation Options:

Delivery only **+£250**

Delivery and Installation without footings **+£650**

Delivery and Installation with footings **+£795**

Delivery and Installation with footings **+£795**

Delivery and Installation with footings **+£795**

Price plus VAT. Prices correct at time of print subject to charge without prior notice.

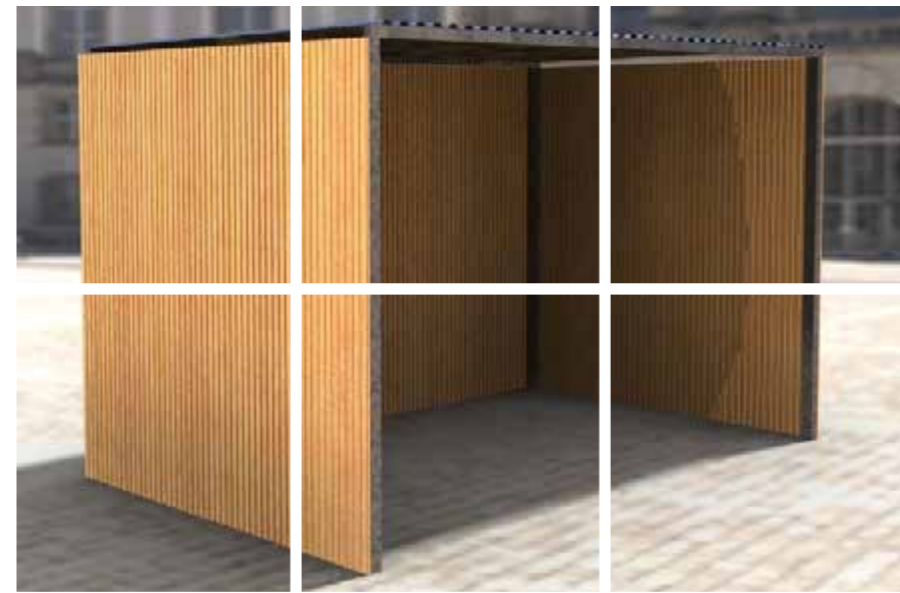
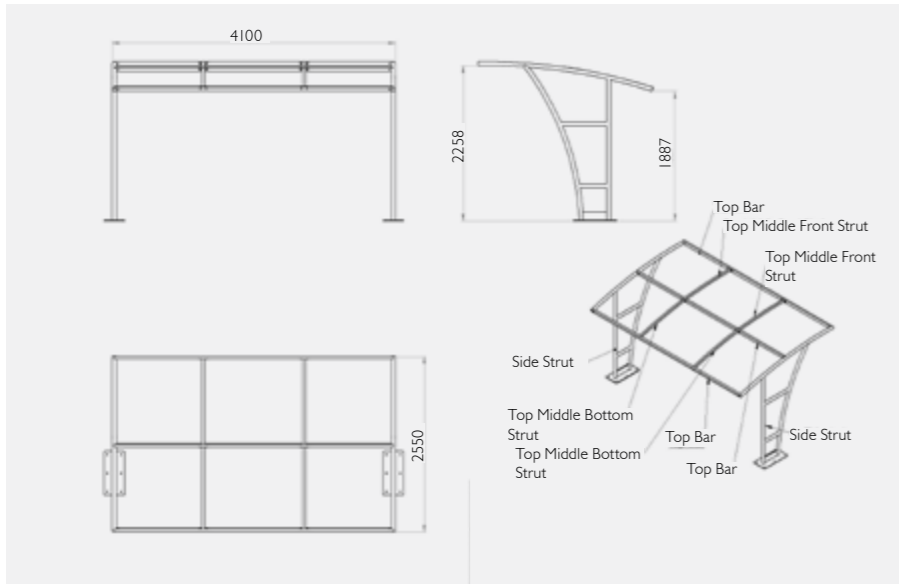

Product Name: Sherwood Wooden Cycle Shelter

Product Description

BREEM AND CODE FOR SUSTAINABLE HOMES COMPLIANT
This bike shelter can help contribute towards gaining ENE8 Cycle storage credits when used in the appropriate situation, under the Code for Sustainable Homes.

Specification

Shelter manufactured from wood with galvanised steel mesh
Galv pressed roof
All fixings to be galvanised or aluminium
Nyloc nuts are used for safety
Angled roof

Installation:

Two ground fixing options
Base plate fixing
Submerged fixing
Free shipping does not apply to our shelter range.

Lead time – Typically 14 days

Costs:

Sherwood Wooden Cycle Shelter - **£1,800 each**

Floor Fixing Options:

Submerged **No charge**

Base Plate Fixing **+£200 each**

Extension Unit Option:

1 x Extension Unit **£1,600 each**

Installation Options:

Delivery only **+£200**

Delivery and Installation without footings- **+£650**

Delivery and Installation with footings- **+£795**

Delivery and Installation with footings- **+£795**

Delivery and Installation with footings- **+£795**

Price plus VAT. Prices correct at time of print subject to charge without prior notice.

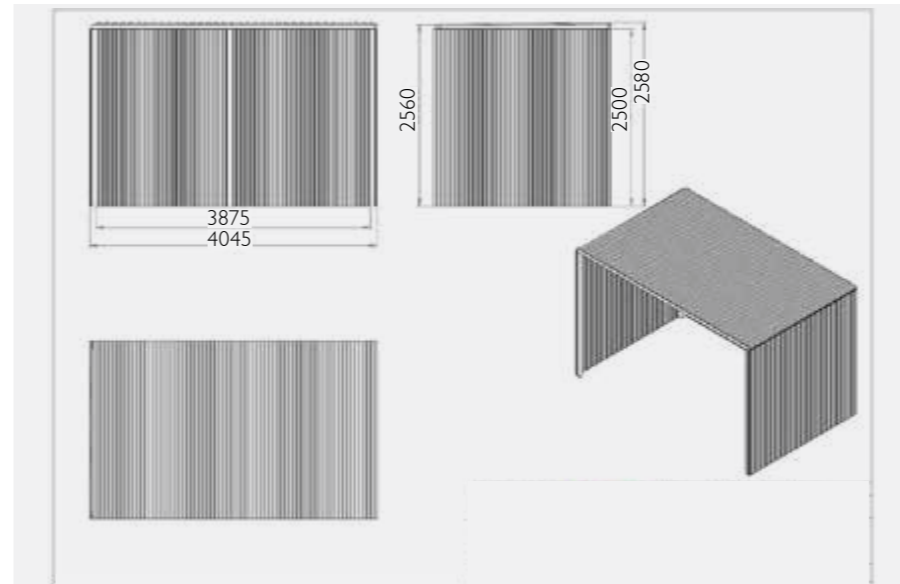

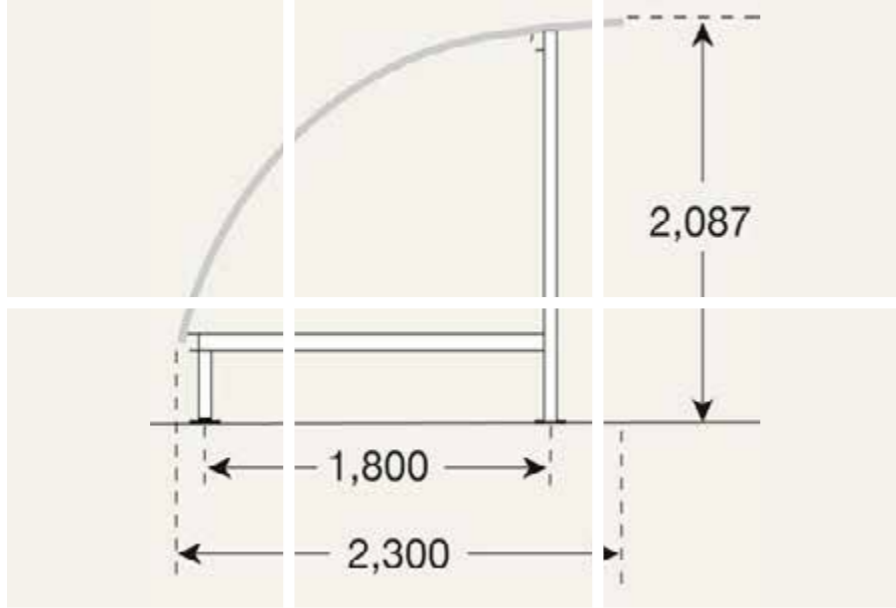
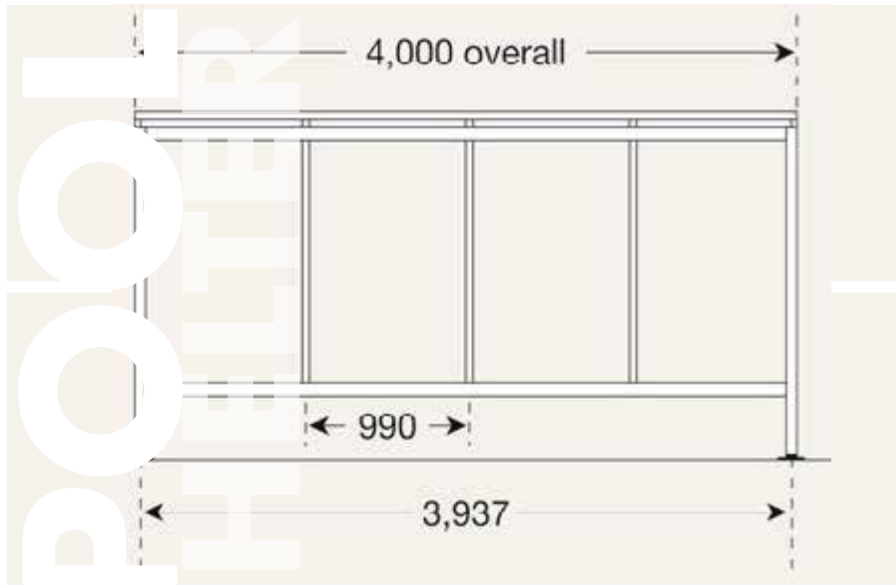

Product Name: Liverpool Cycle Shelter

Product Description

- Easy to assemble and erect
- Modern clean lines
- Clear, tough polycarbonate panels
- Strong galvanised steel frame
- Surface or sub-surface mounted
- Adjustable feet up to 150mm
- Boltless roof assembly

Additional Information

200 x 100 x 140cm
End Panels: RH side, LH side or RH & LH side

Specification:

Width: 398 cm
Height: 209 cm
Depth: 230 cm
Material:
Frame: Steel
Glazing bars: Aluminium
Cover: 4mm Polycarbonate
Finish: Galvanised (Frame), Anodised (Glazing bars)
Options:
4mm Polycarbonate side panels
Ground bolts not included
Delivery time: typically 1-5 working days.

Costs:

Liverpool Cycle Shelter **£2,200 each**

End Panel Options:

RH Side **£530 each**
LH Side **£530 each**
LH & RH Side **£1000 each**

Price includes delivery, Price plus VAT.
Prices correct at time of print subject to charge without prior notice.

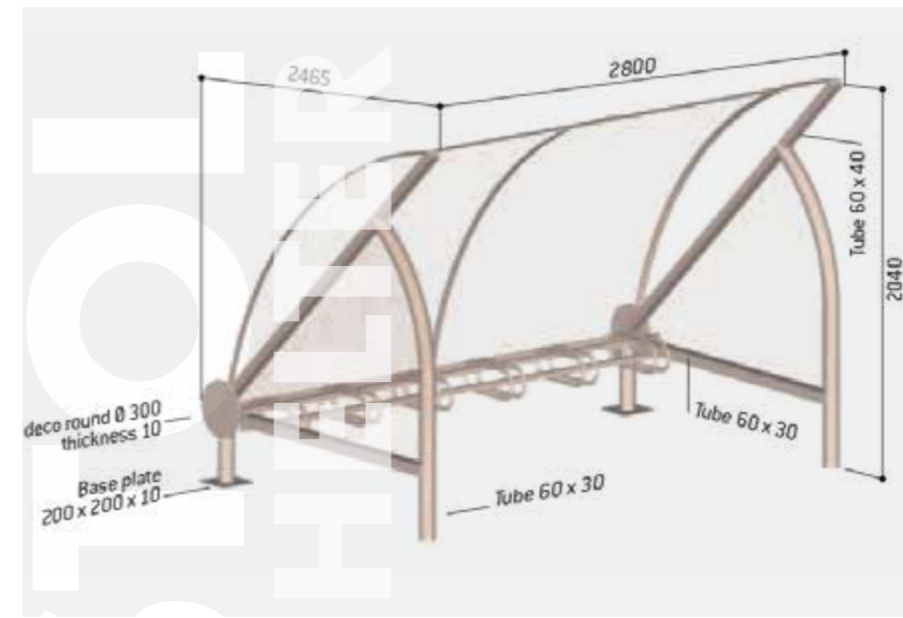

Product Name: Bristol Cycle Shelter

Product Description

Funky style shelter, galvanised and painted. Supporting members and cross beams made from tubular steel assembled by nuts and bolts, caps and washers. Roofing and cladding – Aluminium profile cross member and rainwater gutter. Canopy made of translucent cellular polycarbonate, thickness 6mm, with UV protection. White expanded PVC side cladding, thickness 10mm, supplied in pairs. A 6 space bike stand is included attached to cross beam by stainless steel screws supplied. Extension units are available to double the size and capacity of this shelter, please call for info. Ground bolts included. Delivery time: typically 14-21 working days.

Additional Information

280 x 236 x 211cm

Costs:

Bristol Cycle Shelter **£2,439 each**

Colour Options:

Black, Blue, Red, Green, Grey or Brown

Extension Kit:

1 x Extension **£1,524 each**

Price includes delivery, Price plus VAT.
Prices correct at time of print subject to charge without prior notice.



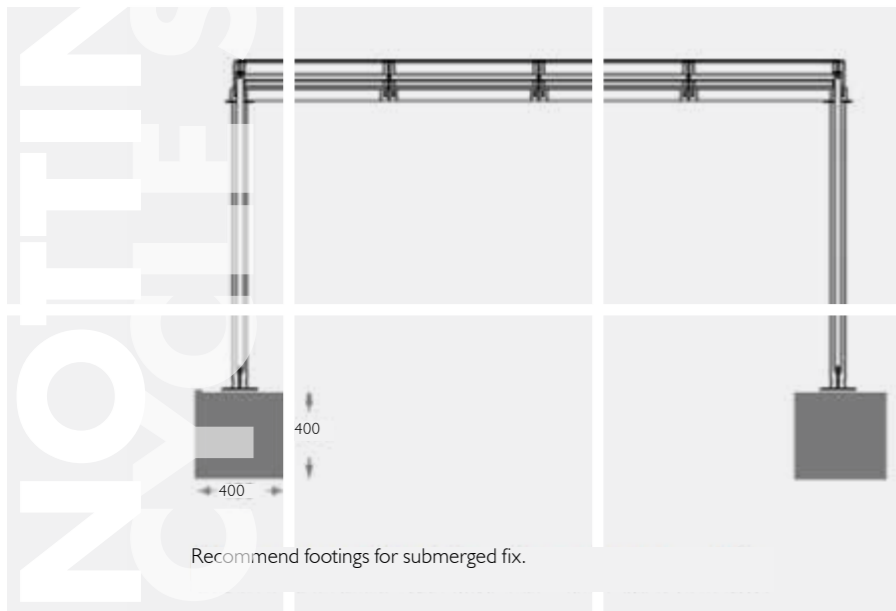
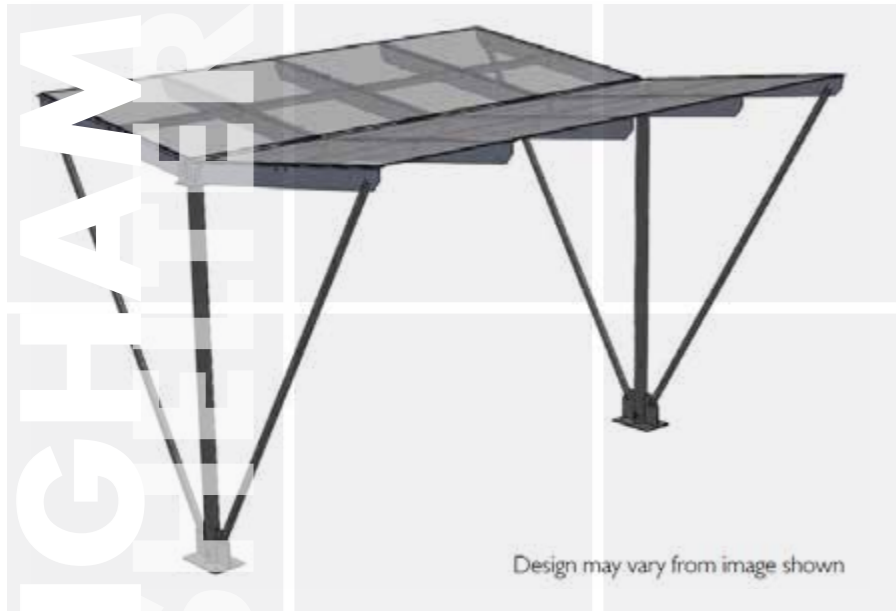
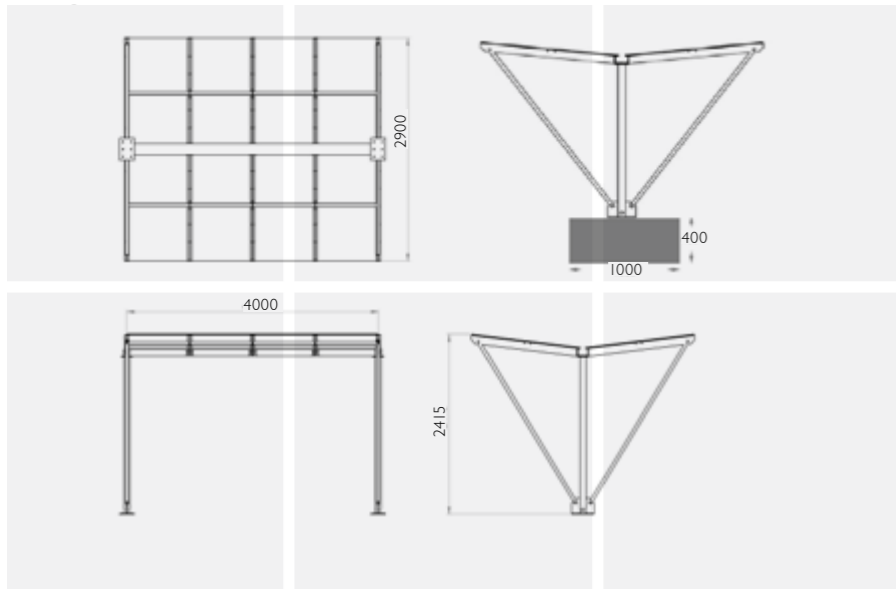

Product Name: Nottingham Cycle Shelter

Product Description

Breem and Code for Sustainable Homes Compliant
This bike shelter can help contribute towards gaining ENE8 Cycle storage credits when used in the appropriate situation, under the Code for Sustainable Homes

Specification

Shelter manufactured from hot dipped steel Galvanised tube section and steel plate to BSEN ISO1461
Transparent PET 4mm roof,
Aluminium fixing straps
All fixings to be galvanised or aluminium
Nyloc nuts are used for safety
Angled roof
Integral guttering

Installation Notes

Two ground fixing options
Base plate fixing
Submerged fixing
Free shipping does not apply to our shelter range.
No Cycle racks provided

Additional Information

Dimensions: 280 x 236 x 211cm
Extension Unit: No Extension Unit, Standard Extension Unit (Up to 10 more Bikes)

Costs:

Nottingham Cycle Shelter **£2,750 each**

Shelter Finish:

Standard Galvanised **£2,750 each**
Powder Coated **£2,950 each**

Installation Options

Delivery only **+£175**
Delivery and Install without footings **+£650**
Delivery and install with footings **+£795 each**

Price plus VAT. Prices correct at time of print subject to charge without prior notice.

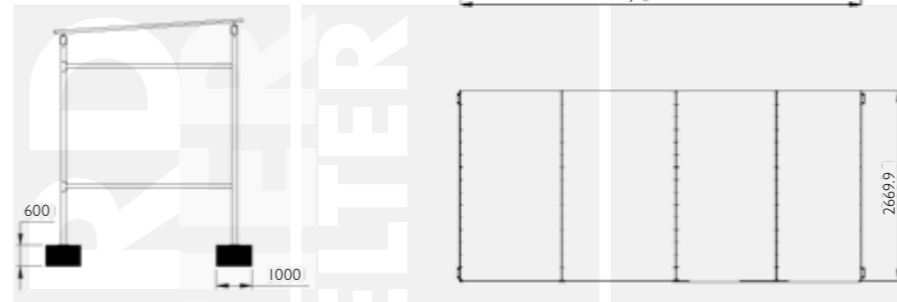
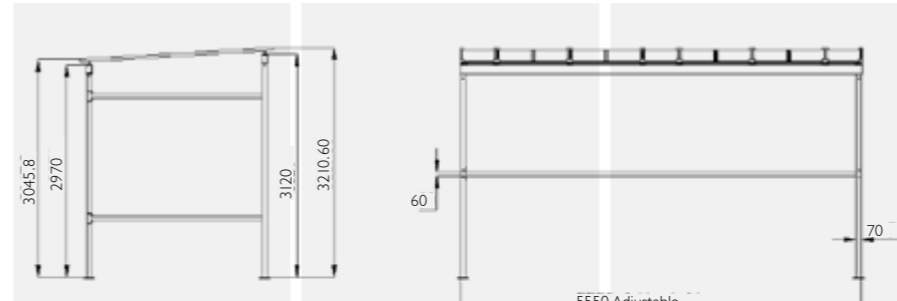

Product Name: Oxford Two Tier Cycle Shelter

Product Description

The Cyclepods Oxford is a Stylish and versatile shelter perfect for all buildings; capable of sheltering up to 24 bikes! In our EasyLift+ Two tier system Extension units can be added to form a larger shelter and house more bikes .

BREEM and Code For Sustainable Homes Compliant

This bike shelter can help contribute towards gaining ENE8 Cycle storage credits when used in the appropriate situation, under the Code for Sustainable Homes

Specification

Shelter manufactured from hot dipped steel Galvanised 60 x 60 box section to BSEN ISO1461
Transparent PET 4mm roof
Optional Transparent PET 4mmsides
Aluminium fixing straps
All fixings to be galvanised or aluminium
Nyloc nuts are used for safety
Angled roof

Installation Notes

Two ground fixing options-
Base plate fixing or Submerged fixing
Free shipping does not apply to our shelter range.
No Cycle racks provided

Additional Information

Weight: 200kg
Dimensions: 555 x 270 310 cm
Standard Colours:



Costs:

Oxford Two Tier Cycle Shelter (Galvanised) **£2,850 each**

Finishing Options:

Powder Coated **£3,050 each**

Installation Options

Delivery only **+£250**
Delivery and Install without footings **+£650**
Delivery and install with footings **+£1,495**

Price plus VAT. Prices correct at time of print subject to charge without prior notice..



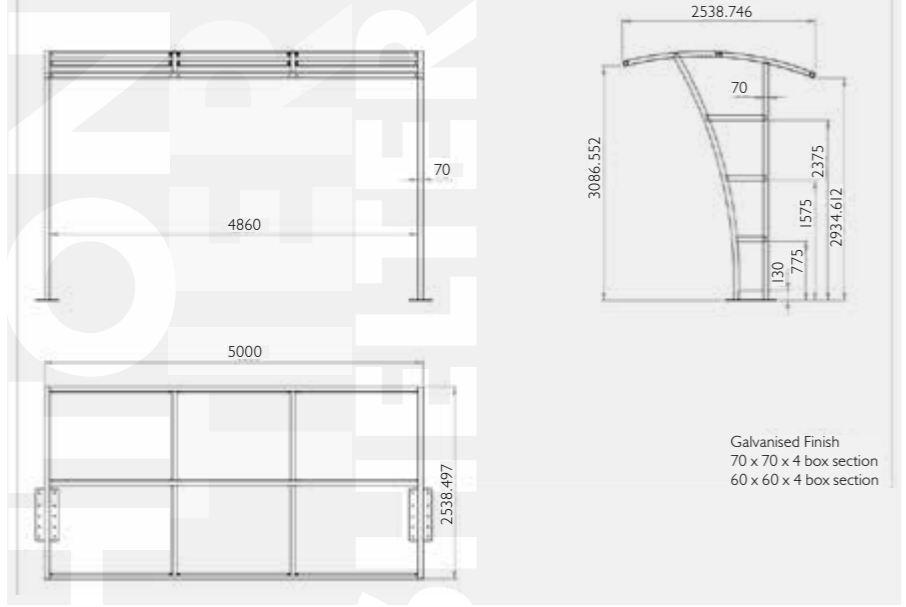

Product Name: Brighton Two Tier Cycle Shelter

Product Description
Bream and Code for Sustainable Homes Compliant

This bike shelter can help contribute towards gaining ENE8 Cycle storage credits when used in the appropriate situation, under the Code for Sustainable Homes

Specification
Shelter manufactured from hot dipped steel Galvanised 70 x 70 box section to BSEN ISO1461
Transparent PET 4mm roof
Aluminium fixing straps
All fixings to be galvanised or aluminium
Nyloc nuts are used for safety
Angled roof

Installation Notes
Two ground fixing options
Base plate fixing
Submerged fixing
Free shipping does not apply to our shelter range.
No Cycle racks provided

Additional Information
Dimensions: 280 x 236 x 211cm
Weight: 180kg

Costs:
Brighton Two Tier Cycle Shelter (Galvanised) £2,950 each

Finishing Options:
Powder Coated £3,150 each

Installation Options
Delivery only +£250
Delivery and Install without footings +£650
Delivery and install with footings +£1,495

Price plus VAT. Prices correct at time of print subject to change without prior notice.

“The Minipods look amazing and the children think they are wonderful, in fact we have a waiting list of children who want to come to school on their bikes!”

Heather White (AdvDip) | Bursar Short Heath Primary School

“Minipods offer a method of cycle storage that is extremely welcomed by our schools, many of which would not have had the space for the traditional sized storage we had been offering until now.”

Greg Harris | School Travel coordinator Lambeth Council

“The 200 Spacepods are popular with our staff and are well used on a daily basis. They are practical, easy to use and their design allows for a number of racks in a limited space.”

Kate Pemberton | Workplace Manager KPMG | Head Office, London

“Cyclepods have been an excellent company to deal with and their minipods have proved really popular with our primary schools”

Kieran Taylor | School Travel Advisor London Borough of Southwark Council

“I just wanted to say a massive thank you from myself, the staff and children at Field End Infant School for our wonderful new mini pods. They are exactly what we were after. It has been a pleasure working with you all and would highly recommend you to any school or setting.”

Amy Lavender | Bursar Field End Infant School

The pods are used regularly by both male and female cyclists who always speak positively about their function. They also provide a great visual message about sustainable travel within our organisation and are regular talking point amount the local community.

Fiona Daly | St Barts and the London Hospital | Environmental Manager

“Cyclepods products ideally tackle the issues of providing an stylish space solution that is also cost-effective and maintenance free”

David Smith | Architect Patience and Highmore Architects

“Spacepods are an elegant, environmentally friendly and extremely efficient solution where space is limited. We have installed 189 Spacepods at our new London HQ and they are proving extremely popular with staff”.

Luke Dodd | Director of Facilities Guardian News and Media

To view our more innovative and alternative bike storage systems, please request our other catalogues.



Cyclepods Ltd

T - 0845 094 0490
F - 0845 094 0151
www.cyclepods.co.uk
info@cyclepods.co.uk

5 Churchill Court,
Hortons Way,
Westerham,
Kent
TN16 1BT

Contact Us

