

# ACO Water Management: Building + Landscape

Uniclass L7315:P4131	EPIC J342: X4122
Cl/SfB (52.6)	

## ACO Wetroom Drainage



### *ACO Wetroom Drainage Systems*

#### **Technical Data**



# Introduction to the ACO Group

Throughout the world ACO branded drainage and surface water management systems are recognised for their innovative design, high quality manufacture, environmental excellence and industry leading performance.

Today the ACO Group has a research and production base that reaches across four continents. This unmatched resource pioneers the development of solutions that are tailored to individual applications, meeting the need for high performance, sustainable products that deliver optimum value throughout their operational life.

## ACO Technologies plc

ACO operates as ACO Technologies plc in the United Kingdom. Founded over 30 years ago, the company has grown quickly on a reputation for design innovation and customer service.

There are now 2 divisions within ACO Technologies that serve every sector of the construction industry, providing solutions for applications as diverse as rail, highways, airports, landscaping, retail, distribution centres and environmentally sensitive projects.



To help architects, designers and contractors meet the legal requirements that now tightly control the way surface water is managed, ACO has created its unique 'Surface Water Management Cycle' – Collect, Clean, Hold, Release – the four core processes now required for the complete and sustainable management of surface water drainage.



# Contents

## **ACO ShowerDrain and Wetroom Systems**

Introduction 4

---

## **ACO ShowerDrain C Channel System**

ShowerDrain C with Horizontal Tanking Flange 5

---

## **ACO Shower Gully Systems**

Gully System for Flexible Sheet or Tiled Flooring 9

Vertical Spigot Slab Penetration Gullies 11

Grating Selection for Gully Systems 12

---

## **Installation, Operation, Care and Maintenance**

Cleaning Methods 14

ACO ShowerDrain C 15

ACO Shower Gully Systems 17



## Introduction to ACO wetroom drainage

Sophisticated, barrier-free bathroom drainage for domestic, hotel, commercial and leisure applications where style, function and performance are pre-requisites.

Level entry wet room showers are easier, safer and more comfortable than standard shower tray designs. They are also much easier to maintain.

ShowerDrain products facilitate easy and convenient conformance to Part M Building Regulations - Access To and Use of Buildings for level access to bathrooms.



4

### ACO ShowerDrain C Line

The ShowerDrain C series is characterised by modern design, perfect functionality and high flow capacity.

### ACO Shower Gully

Compact and attractive stainless steel point gullies for a wide range of applications where capacity is a key factor.



# ACO ShowerDrain C Line

## What is ShowerDrain C Line?

The ShowerDrain C series is characterised by modern design, perfect functionality and high-flow capacity. This high quality stainless steel shower channel system is available with a wide range of gratings and includes the channel body and integrated foul air trap.

The foul air trap is manufactured from corrosion resistant polypropylene. The stainless steel components are pickle passivated; the gratings are brushed to silk gloss.

The ACO ShowerDrain C has been specifically designed for high flow rate capacity, very low construction height and easy maintenance.

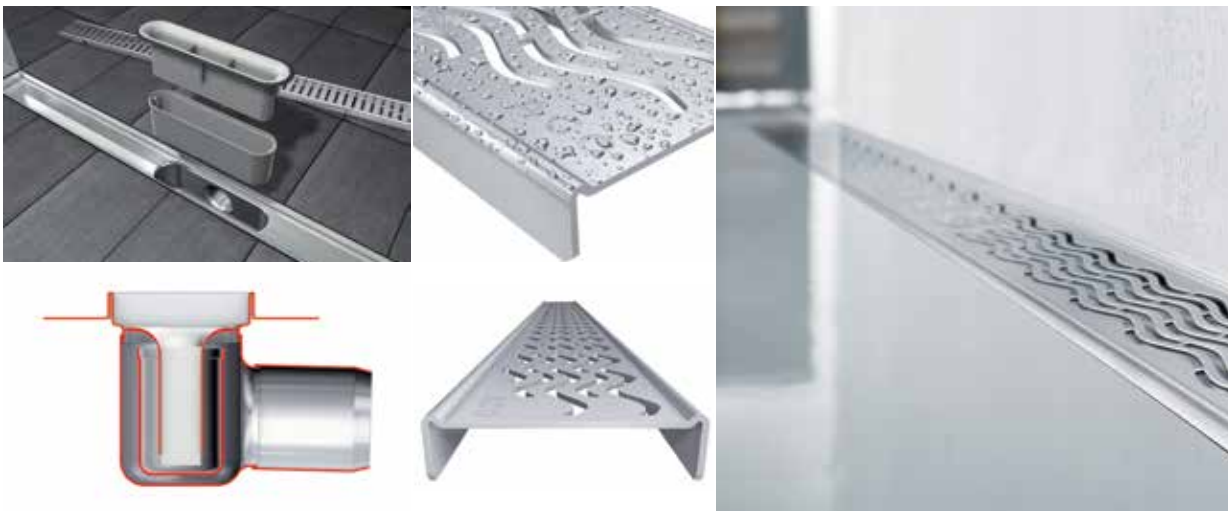

## Features and benefits

- ▶ **Compact shower channel system** - The ACO ShowerDrain C has an overall height of 92mm making it ideal for shallow screed applications.
- ▶ **Easy maintenance** - The user's comfort is increased by the efficiency of the foul air trap and its easy maintenance. The air-tight seal is injection-moulded together with the foul air trap eliminating any risk of lost seals. The foul air trap is easily removed from the shower channel and is easy to dismantle to be cleaned by hand or dish washer.
- ▶ **Versions of ACO ShowerDrain C** - The visible grating width is 70mm and available in 6 lengths – 585mm, 685mm, 785mm, 885mm, 985mm and 1185mm for all solid concrete or timber floor applications.  
  
There are 4 attractive stainless steel grating styles available and brushed to silk gloss.
- ▶ **Gratings** - The stainless steel ShowerDrain C gratings have a unique profile in which the centre section of the grating is lower than the edges. This significantly reduces the risk of overshooting water.



SHOWERDRAIN C WITH HORIZONTAL BONDING FLANGE - FEATURES AND BENEFITS

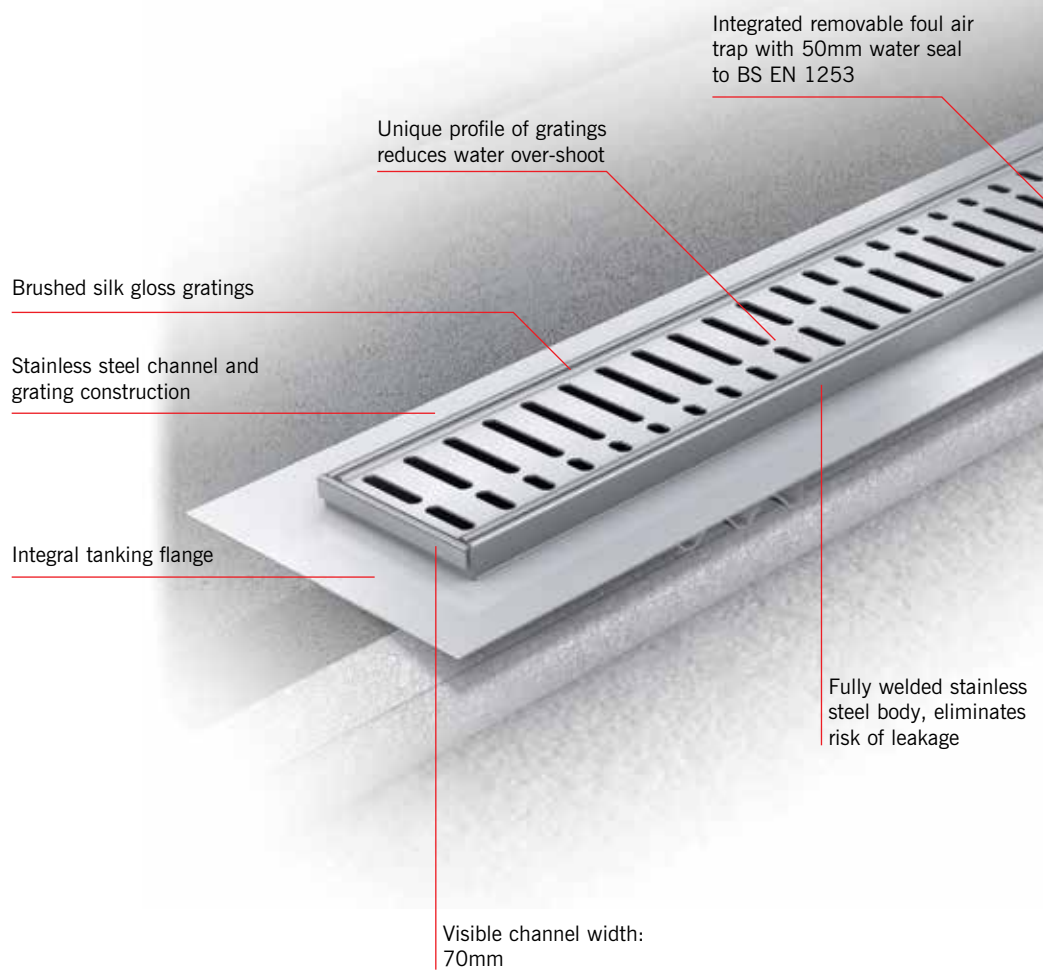

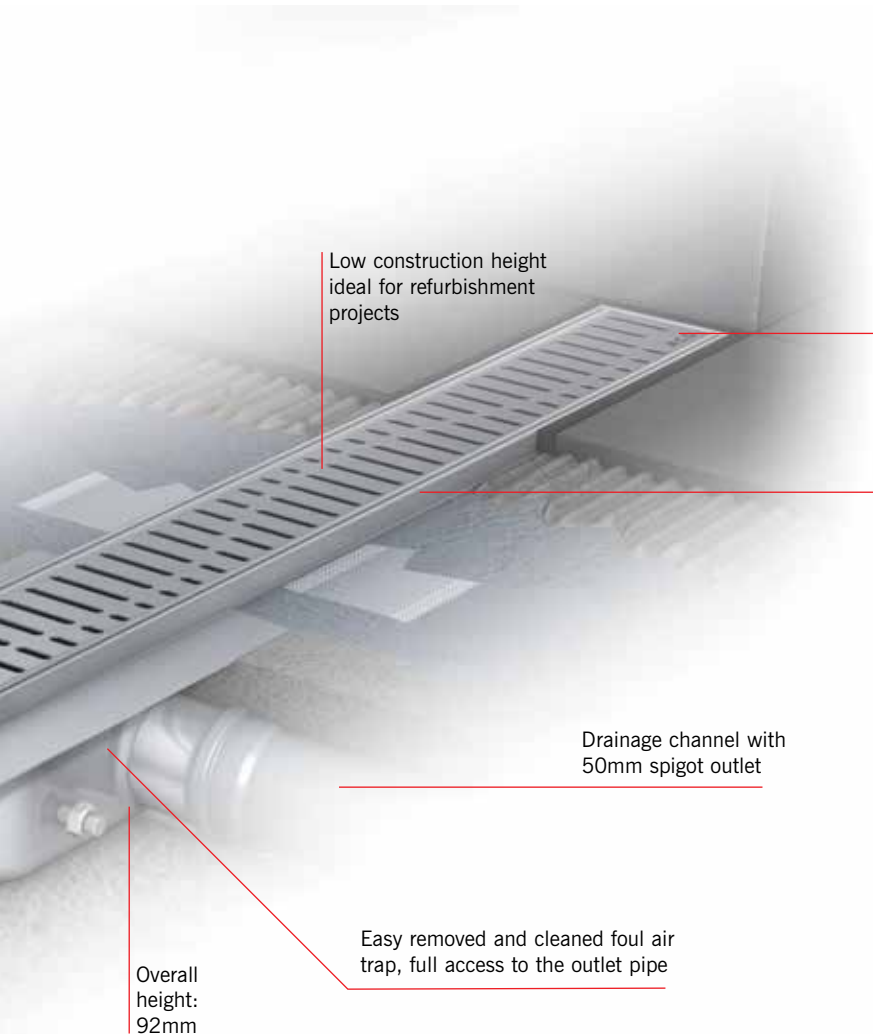

Low construction height  
ideal for refurbishment  
projects

Tested according to BS EN 1253:  
flow rate 0.95 l/s, flow rate at  
entrance of shower: 0.5 l/s, flow  
rate against the wall: 0.8 l/s

Channel body with lateral slope

Drainage channel with  
50mm spigot outlet

Easy removed and cleaned foul air  
trap, full access to the outlet pipe

Overall  
height:  
92mm



## ShowerDrain C with horizontal bonding flange



Length L1 (mm)	Length L2 (mm)	Height H (mm)	Grating			Max tile thickness: 10mm
			Wave	Quadrato	Slot	
585	645	92	404484	404492	403798	408651
685	745	92	404485	404493	403799	408652
785	845	92	404486	404494	403800	408653
885	945	92	404487	404495	403801	408654
985	1045	92	404488	404496	403802	408655
1185	1245	92	404490	404498	403804	408657

8

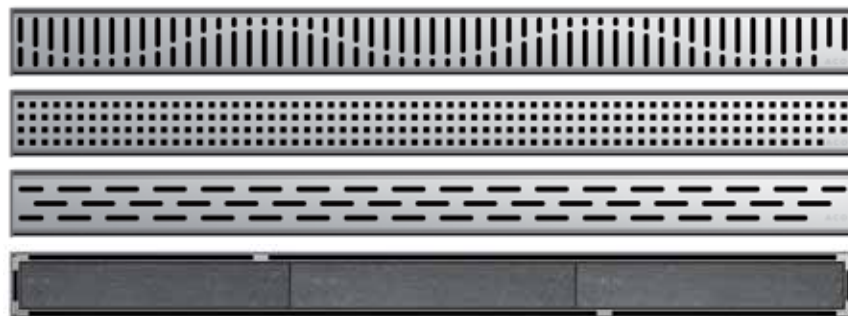



## SHOWER GULLY FEATURES OVERVIEW

- 1 150mm square top tile grating in 8 individual styles. Refer to page 12.
- 2 Barefoot friendly electro-polished stainless steel grating designs.
- 3 Foul air trap conforms to BS EN 1253 requirements for 50mm water seal. High 1.2 l/s flow rate suitable for most modern showers.
- 4 Locked grating for added safety and security.
- 5 Compact horizontal outlet bodies ideal for shallow invert waste pipe connections with easy to install flat bottomed body design to aid installation.
- 6 Vertical outlet spigot options for suspended or solid floor construction.
- 7 Tile grate bezel interfaces with main gully body. Optional grating bezel extension for deep screed applications. Refer page 10.
- 8 Rotational and vertical adjustment on ceramic tile models accommodates orientation, finished floor level and position adjustments.
- 9 Supplied boxed complete with universal 2"/50mm connector and 2"/50mm to 1½"/40mm reducer for easy and convenient connection to horizontal or vertical pipe outlet configuration.
- 10 Square perforated grating available in slip resistant finish that adds style as well as improving wet grip. Refer page 12.

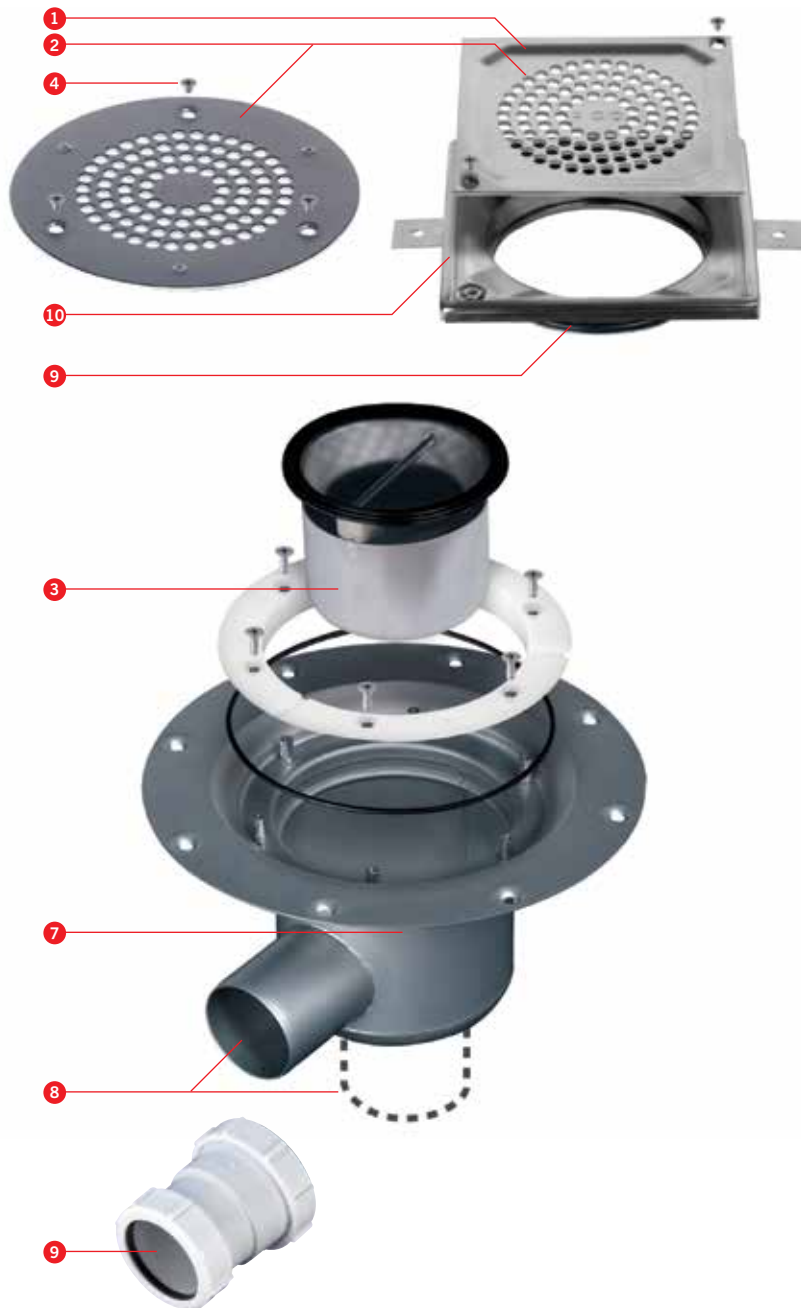

Product code	Description	Flow Rate l/s	Weight kg	Load Class BS EN 1253
405821	50mm Horizontal outlet - tile	1.2	2.3	K3

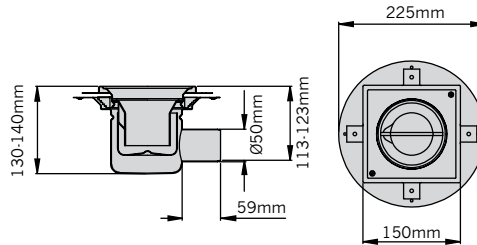

Product code	Description	Flow Rate l/s	Weight kg	Load Class BS EN 1253
405817	50mm Vertical outlet - tile	1.2	2.3	K3

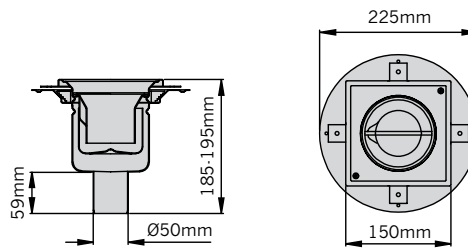

**Optional grating bezel extension - for use with tile options only**

Product code	Description	Weight kg	Overall Gully Height mm
402725	Extension	0.2	162 - 184

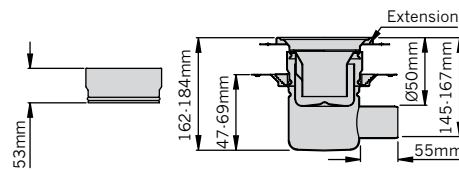

# Vertical spigot slab penetration gullies

Gully bodies with 110mm outlet are available to enable direct connection to below ground drainage where required.

- 1 Telescopic height adjustment providing full 360° rotation and +/- 7.5° pitch and roll adjustment.
- 2 DPM bonding flange.
- 3 Ø110mm vertical spigot trapped outlet.
- 4 Integrated end stops preventing accidental dismantling.

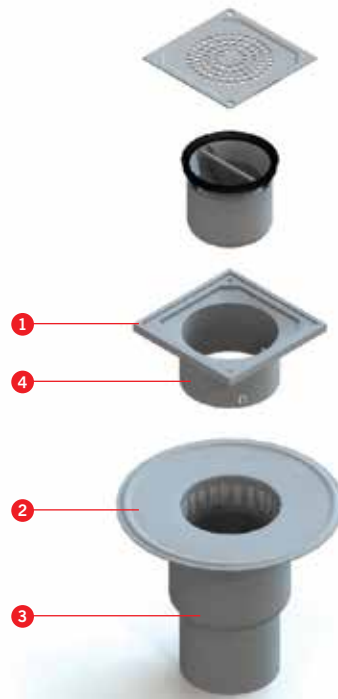

## Vertical spigot slab penetration gullies

Product code	Description	Flow Rate l/s	Weight kg	Load Class BS EN 1253
405854	110mm Vertical outlet - tile	1.2	1.2	K3

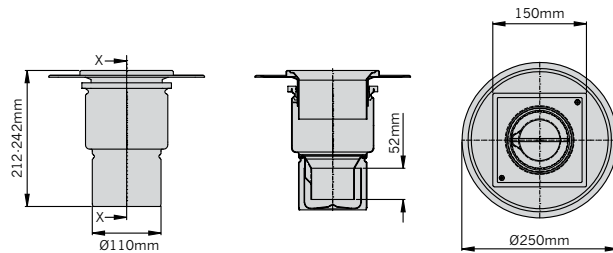

### Grating selections for gully systems

Grating Only Part No 304 Stainless Steel	Grating Style 304 Stainless Steel (electro-polished)	Weight kg	Dimension mm
104039	Quadrato	1.25	135 x 135
104040	Wave	1.25	135 x 135
104041	Mondo	1.25	135 x 135
104043	Wellness	1.25	135 x 135
104044	Classic	1.25	135 x 135
104045	Arco	1.25	135 x 135
401183	Perforated Square	1.25	135 x 135
104047	Slip Resistant Perforated Square	1.25	135 x 135



Quadrato



Wave



Mondo



Wellness



Classic



Arco



Perforated Square



Slip Resistant  
Perforated Square



**Notes:**

1. All gratings are supplied complete with fixings. Maximum waterway inlet slot width: 8mm.
2. All gratings electro-polished stainless steel as standard with the exception of the slip resistant gratings.

# Grating selection for gully systems

## Slip resistant gratings

ACO have developed an attractive, slip resistant finish for their standard gully gratings in response to HSE initiatives relating to reduction of slips and trips in wet environments. The process involves a retexturing of the metal surface and avoids the need for paint-on treatments or fitted inserts. Slip tests in conformance with BS 7976 parts 1-3:2002 carried out on ACO slip resistant gratings reliably exceed the "Low Slip Potential" of SRV36.

## Features and benefits

ACO slip resistant gratings are ideal for shower areas, wet rooms and washdown areas.

- ▶ High slip resistant value - typically SRV60
- ▶ Comfortable for bare feet
- ▶ Corrosion resistant stainless steel, grade 304
- ▶ Attractive two-tone finish
- ▶ Excellent wear qualities
- ▶ No paint-ons
- ▶ No protruding parts

## Tiled flooring



## Vertical spigot slab penetration gullies

Grating Only Part No 304 Stainless Steel	Grating Style	Load Class to BS EN 1253	Suitable For	Weight kg	Dimension mm
104047	Slip resistant perforated square	K3	Tiled cement screed	0.25	135 x 135



# Installation, Operation and Maintenance

## Cleaning Methods

Problem	Cleaning Agent	Comment
Routine cleaning, all finishes.	Soap or mild detergent and water (such as washing up liquid).	Sponge, rinse with clean water, wipe dry if necessary.
Fingerprints, all finishes.	Soap or warm water or organic solvent (e.g. acetone, alcohol).	Rinse with clean water, wipe dry if necessary.
Stubborn stains and discolouration.	Mild cleaning solutions (e.g. Cif, Goddard Stainless Steel Care).	Rinse well with clean water and wipe dry.
Oil and grease marks, all finishes.	Organic solvents (e.g. acetone, alcohol).	Clean after with soap and water, rinse with clean water and dry.
Rust and other corrosion products.	Oxalic acid. The cleaning solution should be applied with a swab and allowed to stand for 15–20 minutes before being washed away with water. May continue using Cif to give final clean.	Rinse well with clean water (precautions for acid cleaners should be observed).
Scratches on Brush (Satin) finish.	Household synthetic fibre scouring pads (e.g. Scotch Brite fibre pad). For deeper scratches apply in direction of polishing. Then clean with soap or detergent as per routine cleaning.	Do not use ordinary steel wool (iron particles can become embedded in stainless steel and cause further surface problems).

Always read instructions on proprietary cleaning agents before use.



### Precautions

Acids should only be used for cleaning when all other methods have been proved unsatisfactory.



# ACO channel systems

## ACO ShowerDrain 'C' Line

### Cleaning & maintenance



i. The grating is retained in the channel body using a friction lock. Remove the grating using the tool supplied by inserting into a slot at the end of the grating and gently pull to remove the grating. Similarly, remove the foul air trap using the same tool as shown below.



ii. Separate the inner and outer sections of the foul air trap by pulling the two components apart. Wash components in warm, soapy water. Rinse and re-assemble foul air trap.



iii. With the grating and channel removed, rinse all stainless steel items in warm soapy water. Wipe dry.

iv. Replace foul air trap and grating. Prime trap with clean water to prevent odours.

## Tiles in joisted acoustic floor

- Where alterations to joists are necessary consult Structural Engineer for advice and reinforce joists as advised. Cut firrings **A** to 1:80 fall towards channel **B** and fix to blocking **C** between joists.
- Lay acoustic overfloor **D** in accordance with manufacturer's instructions, cut rectangular hole and locate shower channel body **B** parallel to joists **E**.
- Bond and fix channel flange **F** using No.8 x 12mm countersunk screws to acoustic floor **D** - fixings **must not** penetrate through top board.
- Connect pipework, laid to fall (hidden detail). Connection to stack should use a flexible pipe coupling to eliminate noise transference. Test for leaks. Provide temporary debris protection to inner channel.
- Apply suitable primer to channel flange **F**.

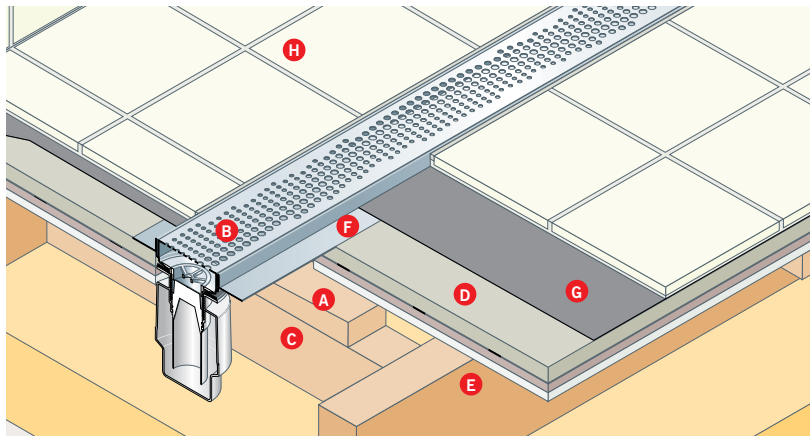

- Apply tanking membrane **G** to whole floor in accordance with manufacturer's instructions. Dress membrane over channel flange **F**.
- Apply tile adhesive working carefully around channel. Lay the ceramic tiles **h**, working away from channel. Leave 8mm gap for grout or flexible sealant at edge of grating frame.

8. Complete all local work and remove temporary protection. Prime trap and fit grating.

### Tiles in suspended concrete floor

1. Form hole **A** in concrete floor to receive shower channel body, trap and outflow pipework.
2. Set fishtail ties **B** on underside of channel to provide key with screed **C** and temporarily support all components to required finished floor level. Provide temporary debris protection to inner channel.
3. Lay screed **C** to 1:80 fall ensuring fishtail ties are fully keyed in.
4. Connect pipework **D**, laid to fall and test for leaks.
5. Inject fire retardant polyurethane expanding foam **E** into void around drain body, trap and pipework to provide additional support.
6. Apply suitable primer to channel flange **F**.

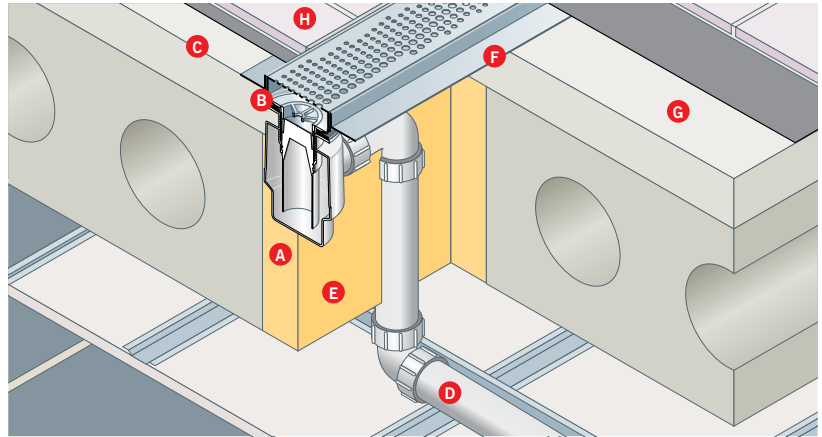

7. Apply tanking membrane **G** to whole floor screed in accordance with manufacturer's instructions. Dress membrane over channel flange **F**.
8. Apply tile adhesive working carefully around the channel. Lay ceramic tiles **H** working away from channel. Leave 8mm gap for grout or flexible sealant at edge of grating frame.
9. Complete all local work and remove temporary protection. Prime trap and fit grating.

### Tiles in ground floor

1. Form recess in slab to accommodate trap prior to laying DPM **A**. Lay DPM.
2. Set fishtail ties **B** to provide key with concrete backfill **C**. Temporarily support all components to required finished floor level.
3. Connect pipework **D** to fall, discharging to back inlet gully and test for leaks. Provide temporary debris protection to inner channel.
4. Box out and backfill concrete **C** around trap and channel ensuring fishtails are fully keyed-in.
5. Remove shutters and lay insulation **E** forming 20mm duct **F** around pipe to receive polystyrene bead fill.
6. Lay screed **G** to 1:80 fall.
7. Apply suitable primer to channel flange **H**.

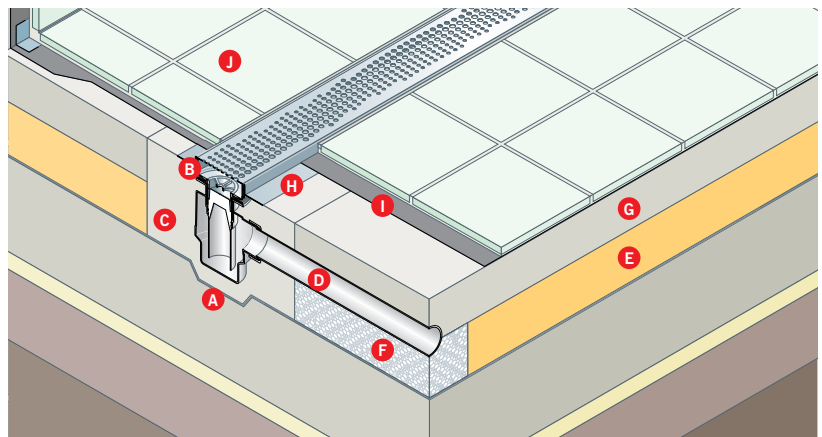

8. Apply tanking membrane **I** to whole floor screed in accordance with manufacturer's instructions. Dress membrane over channel flange **H**.
9. Apply tile adhesive working carefully around the channel. Lay ceramic tiles **J** working away from channel. Leave 8mm gap for grout or flexible sealant at edge of grating frame.
10. Complete all local work and remove temporary protection. Fit and prime trap. Fit grating.





# ACO shower gully systems

## Servicing of foul air trap



1. Remove crosshead screws from grating. Using appropriate gloves, grip the crossbar of the foul air trap and pull upwards making sure that the rubber sealing ring does not dislocate and fall into the drain. Remove sealing ring. Clean foul air trap thoroughly with soapy water.
2. Lubricate the sealing ring with petroleum jelly and carefully locate the ring back onto the foul air trap. Lubricate the gully body in the area where the sealing ring will locate. Push the foul air trap firmly into position making sure that the trap seats squarely and that the sealing ring remains in position. Replace grating and tighten until resistance is felt.

## Tiles in joisted acoustic floor

1. Where alterations to joists are necessary consult Structural Engineer for advice and reinforce joists as advised. Cut firrings **A** to 1:80 fall in four directions towards gully **B**.
2. Lay acoustic over-floor **C** in accordance with manufacturer's instructions, cut circular hole to fully support flange **D** and location of drain body. Rebate flange, bond and fix using non ferrous No.8 x 12mm screws - fixings **must not** penetrate through acoustic top board. Provide temporary debris protection to inner drain.
3. Connect pipework **E**, laid to fall, using coupling provided. (Connection to stack should use a flexible pipe coupling to eliminate noise transference). Test for leaks.
4. Apply primer to drain flange **D**.
5. Apply tanking membrane **F** to whole floor in accordance with manufacturer's instructions. Dress membrane over drain flange **D** and fix clamp ring, ensuring tanking membrane is securely clamped.
6. Adjust grating frame **H** to finished floor level and protect grating for duration of building work.
7. Apply tile adhesive working carefully around the drain. Lay the ceramic tiles **G** working away from drain. Leave 8mm gap for grout or flexible sealant at edge of grating frame.
8. Complete all local work and remove temporary protection. Fit and prime trap. Fit grating.

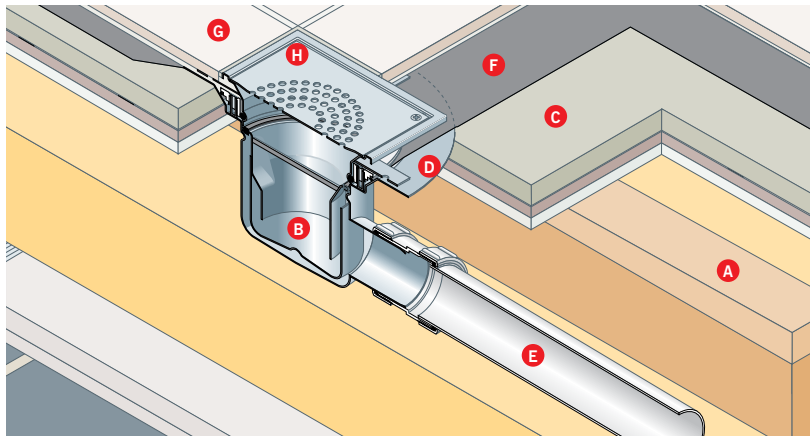

### Tiles in ground floor

1. Box out around drain pipe and cast concrete floor slab **A**.
2. Remove shuttering and connect drain body to pipe. Test pipework for leaks and provide temporary debris protection to inner drain. Backfill concrete **B** around drain body.
3. Lay DPM **C** over floor slab and seal to drain body. Lay insulation **D** and fit around drain body **E**. Remove temporary protection and push fit tanking flange **F** into seal within drain body. Adjust to required screed height and replace temporary protection.
4. Lay screed **G** to 1:80 fall.
5. Remove temporary protection, push fit grating frame **H** into tanking flange **F** and adjust to finished floor level. Provide temporary protection for duration of building works.

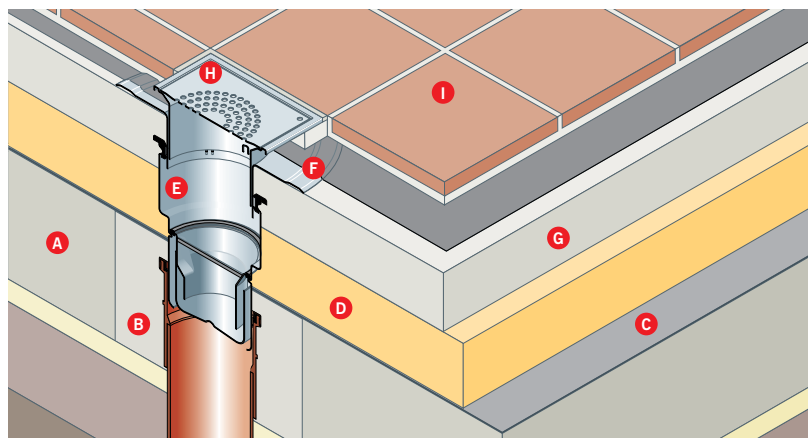

6. Apply tanking membrane to whole floor in accordance with manufacturer's instructions. Dress membrane over tanking flange **F** and around bezel.
7. Apply tile adhesive working carefully around drain. Lay quarry tiles **I**, working away from drain. Leave 8mm gap for grout or flexible sealant at edge of grating frame.
8. Complete all local work and remove temporary protection. Fit and prime trap. Fit grating.

### Tiles in suspended concrete floor

1. Lay screed **A** to 1:80 fall over structural floor and cast or core drill circular hole through screed and concrete floor.
2. Position drain body in hole and bond drain flange **B** to screed. Provide temporary debris protection to inner drain.
3. Connect pipework **C**, laid to fall, using coupling provided and test for leaks.
4. Inject expanding fire retardant polyurethane foam **D** into void around drain body and pipework to provide additional support.
5. Apply primer to drain flange **B**.
6. Apply tanking membrane **E** to whole floor in accordance with manufacturer's instructions. Dress membrane over drain flange **B** and fix clamp ring, ensuring tanking membrane is securely clamped.

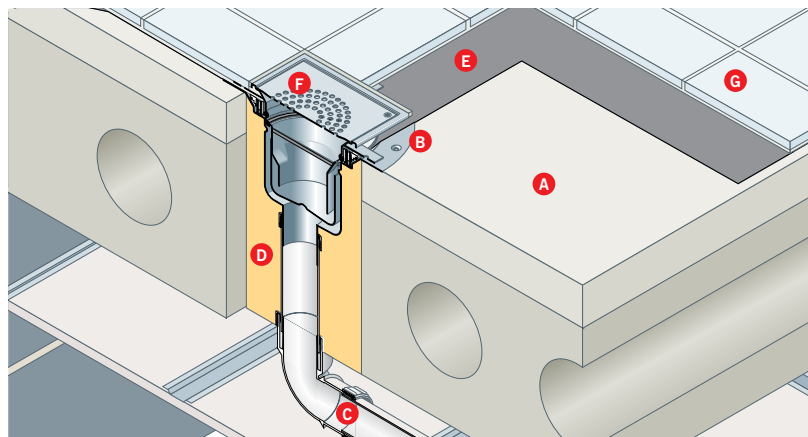

7. Adjust grating frame **F** to finished floor level and protect for duration of work.
8. Apply tile adhesive working carefully around the drain. Lay the ceramic tiles **G**, working away from drain. Leave 8mm gap for grout or flexible sealant at edge of grating frame. Fit and prime trap. Fit grating.





## ACO Technologies plc

- ACO Water Management  
Civils + Infrastructure  
Building + Landscape
- ACO Building Drainage
- ACO Sport
- ACO Wildlife



ISO 9001  
FM 13502



ISO 14001  
EMS 538781



OHSAS 18001  
OHS 524145



### ACO Water Management

A division of ACO Technologies plc  
ACO Business Park,  
Hitchin Road,  
Shefford,  
Bedfordshire  
SG17 5TE

Tel: 01462 816666

Fax: 01462 815895

e-mail Enquiries: [awmenquiries@aco.co.uk](mailto:awmenquiries@aco.co.uk)

e-mail Sales: [customersupport@aco.co.uk](mailto:customersupport@aco.co.uk)

e-mail Technical: [technical@aco.co.uk](mailto:technical@aco.co.uk)

website: [www.aco.co.uk](http://www.aco.co.uk)

### The ACO Group: A strong family you can depend on.

© December 2016 ACO Technologies plc. All reasonable care has been taken in compiling the information in this document. All recommendations and suggestions on the use of ACO products are made without guarantee since the conditions of use are beyond the control of the Company. It is the customer's responsibility to ensure that each product is fit for its intended purpose, and that the actual conditions of use are suitable. This brochure and any advice is provided by ACO Technologies plc (the Company) free of charge and accordingly on terms that no liability including liability for negligence will attach to the Company or its servants or agents arising out of or in connection with or in relation to this brochure or any such advice. Any goods supplied by the Company will be supplied solely upon its standard conditions of sale, copies of which are available on request. The Company's policy of continuous product development and improvement renders specifications liable to modification. Information provided in this brochure is therefore subject to change without prior notification.

#### ACO CARES ABOUT THE ENVIRONMENT

Printed on material certificated in accordance with the rules of the FSC who provide a means of assuring that products come from responsibly managed forest.