

Uniclass L731:P4131	March 2012
CI/SfB (52.9)	

ACO Building Drainage

Pipework Systems

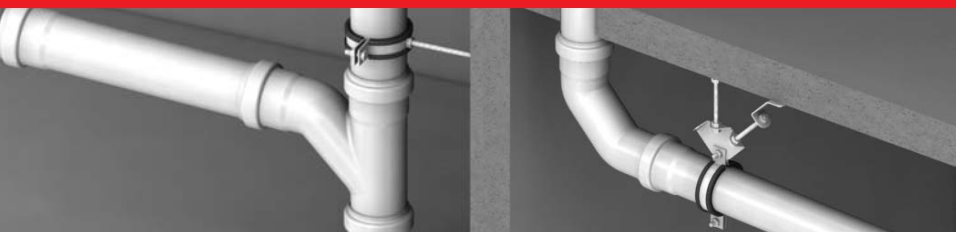

Product catalogue

ACO PIPE® Stainless Steel Pipework Systems



ACO Building Drainage

Our built environment is becoming ever more complex. Applications are becoming more sophisticated and the increasing pressure of regulations and standards make achieving design, performance and financial goals ever tougher.

ACO Building Drainage is a new concept within the ACO Group. Our mission: to eliminate design risk, to reduce installed and life cost and to deliver exceptional finish and performance in every product application.

We achieve this through three factors:

- High performance materials
- Design experience and project support
- Global manufacturing capacity

Our global resources and fabrication capacity make it possible for us to deliver best value, both with our standard products and with our bespoke designs. Confidence is further assured with quality systems that are in accordance with ISO 9001-2008.

ACO Building Drainage's extensive portfolio includes:

- Stainless steel socketed pipe system
- Stainless steel gullies
- Standard stainless steel and galvanised steel channels
- Bespoke channel drainage systems
- Roof/Balcony drainage systems
- Stainless steel and aluminium access covers
- Anti-flood backflow protection systems
- Wetroom and shower drainage
- Grease Management systems

ACO Building Drainage is a division of ACO Technologies plc and part of the worldwide ACO Group. The Group has sales in excess of £600 million worldwide with production facilities in the UK, Germany, France, Switzerland, Denmark, Spain, Poland, Czech Republic, Australia and the USA. In total more than 3500 people are employed in 40 countries throughout the world.

Tel: 01462 816666

Fax: 01462 851490

e-mail Enquiries: buildingdrainage@aco.co.uk

website: www.acobuildingdrainage.co.uk



Contents

General introduction	
Introduction	4
Typical applications	4
Product benefits	4
ACO PIPE® material information	5
Push-fit connection	5
Sound	5
Reaction to fire	5
Characteristics and system overview	6
ACO PIPE® family ranges overview	
ACO PIPE® family ranges overview	7
Product ranges	10
Flow rates and operating pressure	
Full bore flow rate tables for varying gradients	48
Operating pressure	49
Installation guide	
Installation guide	50
ACO PIPE® material information	
Pipe material information	54
Seal material information	55
Care and maintenance	
Maintenance programme	56
Precautions	56
Conclusion	56
Material resistance chart	
Material resistance chart	57
Notes	
Notes	59



General introduction

Stainless steel pipework

The ACO Building Drainage name is synonymous with the highest standards in product design, range diversity and function for industrial, commercial and architectural drainage products manufactured in stainless steel.

As part of a growing range of engineered drainage solutions, ACO PIPE® presents a wide range of socketed waste pipework systems in thin-wall stainless steel for above and below ground drainage applications.

ACO PIPE® is reliable, lightweight and durable push-fit pipework system, designed, produced and tested for soil, waste, rainwater and industrial wastewater drainage applications.

ACO PIPE® stainless steel socketed pipe systems provide the modern metal alternative to PVC-u and cast iron soil and waste pipework.

Together with the other products of ACO Group it creates a perfect system and offers a sustainable drainage solution with unique advantages to the customers. Especially with the ACO gully and ACO stainless steel channel systems provide a unique system for building drainage. The push-fit system ensures quick and easy assembly for a reliable installation for gravity and vacuum drainage.

All ACO PIPE® interconnecting seals and fittings incorporate a unique double sealing system providing a trouble-free, reliable sealing system – every time.

The wide range of fittings available utilises advanced cold forming techniques, thereby reducing the manufacturing cost and minimizing the amount of welded components, to provide the ultimate in system reliability.

More than 1,500 different types are available (straight pipes, bends, branches, diameter increasers and reducer's) together with a wide range of accessories this creates a complex and complete system for pipework construction – the ACO PIPE® system.



Typical applications

ACO PIPE® stainless steel pipe is the fast track alternative to cast iron or PVC-u pipe systems and is available in standard and non-standard pipe sizes with easy to assemble push-on fittings. ACO PIPE® is ideal for:

- Food processing plants
- Commercial buildings
- Chemical processing plant
- Industrial buildings
- Hotels
- Kitchens
- Leisure centres
- Hospitals
- Laboratories
- Schools
- Abattoirs

Product benefits

ACO PIPE® socketed stainless steel systems significantly reduces installation time and associated costs along with long term maintenance and care costs.

- Easy installation
- Highly corrosion resistant
- Lightweight and easy to handle
- Double sealed jointing system
- Simple push-fit assembly
- Low thermal expansion coefficient
- No painting required
- Aesthetically pleasing
- Electro-polished option
- Sustainable material
- Hygienic

General introduction

ACO PIPE® material information

ACO PIPE® stainless steel pipework systems are manufactured from austenitic stainless steel in grades 304 and 316. All products are chemically pickled passivated for optimum durability and corrosion resistance.

Surface treatment by means of electropolishing or varnishing is available. Recognised for long service and its easily cleaned characteristics, stainless steel's hard, smooth surface provides efficient flow for water and waste products.

ACO PIPE® sockets are fitted with EPDM seals as standard for regular drainage applications above and below ground. For particularly aggressive chemical applications, 316 grade stainless steel with Viton® seals can be specified for the ultimate in system durability.

Push-fit connection

Very reliable for vacuum and gravity piping system.

ACO PIPE® double lip seal for ultimate system reliability. The unique and sophisticated design of the lips and cavities gives ACO PIPE® full liquid-tight sealing.

- Push-fit advantages
- Easy to assemble
- Time saving
- Cost saving
- Water tight connection



Sound

Results of acoustic tests on ACO PIPE® performed to BS EN 13466 are available on the website or upon request.

Reaction to fire

ACO PIPE® push-fit system is designed and manufactured to BS EN 1124 Parts 1 & 2 and is non-combustible and classified as Class A 'No contribution to fire' as provided for in Commission Decision 96/603/EC as amended.

ACO PIPE® systems are also certified by the Swedish Institute for Technical Approval in Construction (SITAC) as fire resistant, Certificate No 0410-01.

- Non combustible
- No additional fire collars needed at installation
- No toxic fumes emitted in case of fire
- BS EN 1124, SITAC, CSI, DNV and ABS fire certification available



General introduction

Characteristics and system overview

ACO PIPE® is the ideal system for grey and black water, rainwater and industrial waste water drainage applications. Use in conjunction with ACO stainless steel gully and channel systems to provide a complete building drainage solution.

ACO PIPE® stainless steel pipes and fittings are available in 50mm, 75mm, 110mm, 125 mm, 160mm and 200mm external diameters with the standard lengths from 0.15 metre up to 6 metres for optimum practicality and ease of assembly.

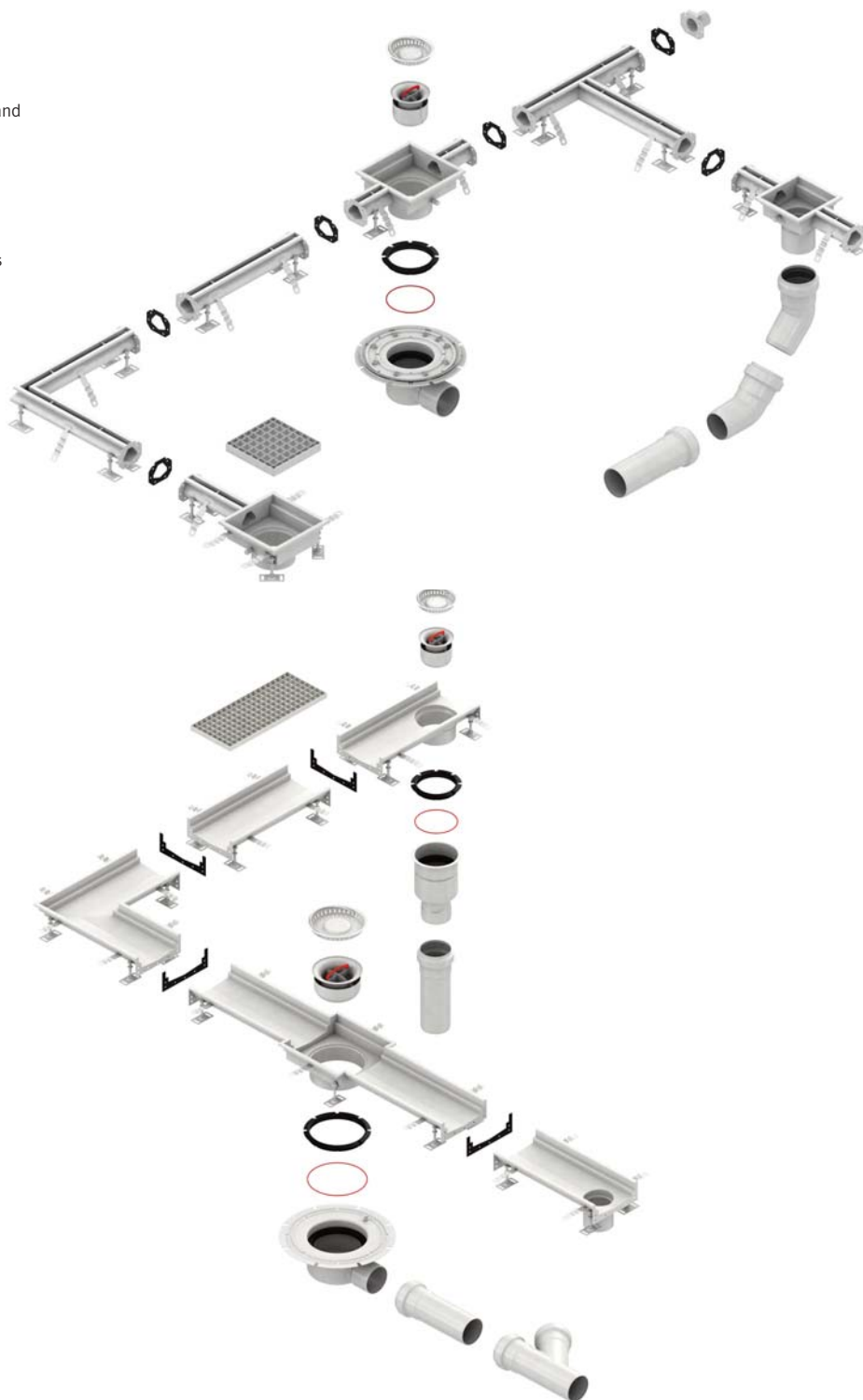

ACO PIPE® family ranges overview

Dimensions of socket and spigot for all pipe sizes



D (mm)	D1 (mm)	D2 (mm)	D3 (mm)	Socket length, L (mm)	Wall thickness, T (mm)
50	51	62.0	47	42	1
75	76	87.5	72	50	1
110	111	125.5	107	57	1
125	126	141.0	122	63	1
160	161	178.0	156	70	1.25
200	201	219.0	195	80	1.5

Table 1

ACO PIPE® family ranges overview

Socketed pipes	Page 10	Bends	Page 22	Single branches	Page 25
Double branches	Page 27	Double branch reductions	Page 31		
Swept single branches	Page 32	Swept branch special	Pages 26, 27	Swept branch reduction special	Page 29, 31

Note: Contact ACO Building Drainage on 01462 816666 for non-standard branch geometry requirements.

ACO PIPE® family ranges overview

<p>"P" traps Page 33</p> 	<p>Couplings Page 34</p> 	<p>Connectors Page 37</p> 
<p>Access units Page 40</p> 	<p>Rat-stop pipes Page 41</p> 	<p>Socket plugs Page 41</p> 
<p>Socket clamps Page 42</p> 	<p>Vent cowl Page 42</p> 	<p>Seals Page 43</p> 

Note: Contact ACO Building Drainage on 01462 816666 for non-standard branch geometry requirements.



Product ranges

Features

- Pipes and fittings are available in 50 mm, 75mm, 110mm, 125mm, 160mm and 200mm external diameters
- Lengths from 0.15 metre up to 6 metres
- Fully compliant to BS EN 1124-1 and BS EN 1124-2
- Available in 304 and 316 grades of stainless steel
- EPDM and Viton® seals available
- Push-fit system for quick assembly
- Fully pickle passivated

50mm socketed pipe



Seal material	D (mm)	Active length L (mm)	Weight (kg)	Part No 304	Part No 316
EPDM	50	150	0.2	98500	98550
	50	250	0.4	98502	98552
	50	500	0.7	98504	98554
	50	750	1.0	98506	98556
	50	1000	1.3	98508	98558
	50	1500	1.9	98510	98560
	50	2000	2.6	98512	98562
	50	2500	3.2	419274	419282
	50	3000	3.8	98514	98564
	50	4000	5.0	419458	419482
	50	5000	6.3	419466	419490
Viton	50	6000	7.5	419474	419498
	50	150	0.2	98501	98551
	50	250	0.4	98503	98553
	50	500	0.7	98505	98555
	50	750	1.0	98507	98557
	50	1000	1.3	98509	98559
	50	1500	1.9	98511	98561
	50	2000	2.6	98513	98563
	50	2500	3.2	419275	419283
	50	3000	3.8	98515	98565
	50	4000	5.0	419459	419483
50	5000	6.3	419467	419491	
50	6000	7.5	419475	419499	

Table 2

Product ranges

75mm socketed pipe

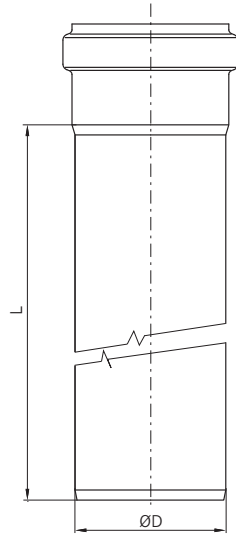

Seal material	D (mm)	Active length L (mm)	Weight (kg)	Part No 304	Part No 316
EPDM	75	150	0.4	98516	98566
	75	250	0.6	98518	98568
	75	500	1.0	98520	98570
	75	750	1.5	98522	98572
	75	1000	2.0	98524	98574
	75	1500	2.9	98526	98576
	75	2000	3.6	98528	98578
	75	2500	4.8	419276	419284
	75	3000	5.7	98530	98580
	75	4000	7.6	419460	419484
	75	5000	9.4	419468	419492
75	6000	11.3	419476	419500	
Viton	75	150	0.4	98517	98567
	75	250	0.6	98519	98569
	75	500	1.0	98521	98571
	75	750	1.5	98523	98573
	75	1000	2.0	98525	98575
	75	1500	2.9	98527	98577
	75	2000	3.6	98529	98579
	75	2500	4.8	419277	419285
	75	3000	5.7	98531	98581
	75	4000	7.6	419461	419485
	75	5000	9.4	419469	419493
75	6000	11.3	419477	419501	

Table 3

Product ranges

110mm socketed pipe

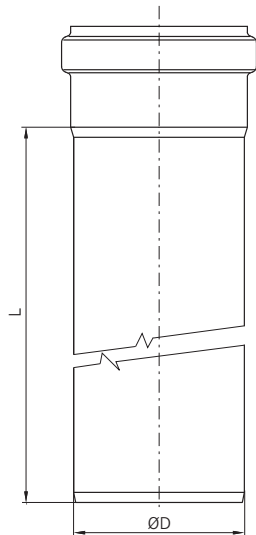

Seal material	D (mm)	Active length L (mm)	Weight (kg)	Part No 304	Part No 316
EPDM	110	150	0.6	98532	98582
	110	250	0.9	98534	98584
	110	500	1.5	98536	98586
	110	750	2.2	98538	98588
	110	1000	2.9	98540	98590
	110	1500	4.3	98542	98592
	110	2000	5.7	98544	98594
	110	2500	7.1	419278	419286
	110	3000	8.4	98546	98596
	110	4000	11.1	419462	419486
Viton	110	5000	13.9	419470	419494
	110	6000	16.7	419478	419502
	110	150	0.6	98533	98583
	110	250	0.9	98535	98585
	110	500	1.5	98537	98587
	110	750	2.2	98539	98589
	110	1000	2.9	98541	98591
	110	1500	4.3	98543	98593
	110	2000	5.7	98545	98595
	110	2500	7.1	419279	419287
	110	3000	8.4	98547	98597
	110	4000	11.1	419463	419487
110	5000	13.9	419471	419495	
110	6000	16.7	419479	419503	

Table 4

Product ranges

125mm socketed pipe

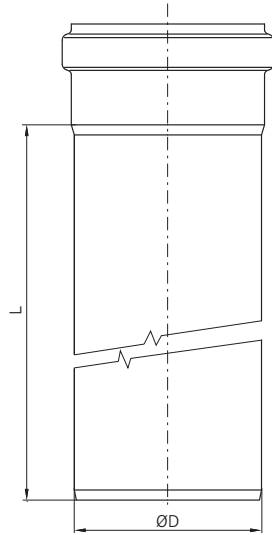

Seal material	D (mm)	Active length L (mm)	Weight (kg)	Part No 304	Part No 316
EPDM	125	150	0.7	419692	419712
	125	250	1.0	419694	419714
	125	500	1.7	419696	419716
	125	750	2.5	419698	419718
	125	1000	3.3	419700	419720
	125	1500	4.9	419702	419722
	125	2000	6.5	419704	419724
	125	2500	8.1	419708	419728
	125	3000	9.6	419706	419726
	125	6000	19.0	419710	419730
Viton	125	150	0.7	419693	419713
	125	250	1.0	419695	419715
	125	500	1.7	419697	419717
	125	750	2.5	419699	419719
	125	1000	3.3	419701	419721
	125	1500	4.9	419703	419723
	125	2000	6.5	419705	419725
	125	2500	8.1	419709	419729
	125	3000	9.6	419707	419727
	125	6000	19.0	419711	419731

Table 5

Product ranges

160mm socketed pipe

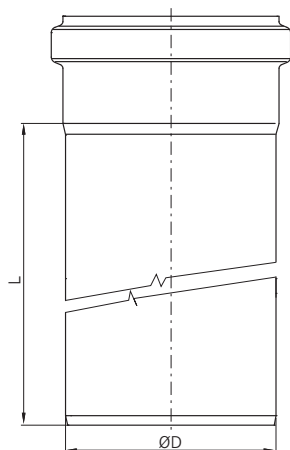

Seal material	D (mm)	Active length L (mm)	Weight (kg)	Part No 304	Part No 316
EPDM	160	150	1.1	98548	98598
	160	250	1.6	98600	98650
	160	500	2.9	98602	98652
	160	750	4.1	98604	98654
	160	1000	5.4	98606	98656
	160	1500	7.9	98608	98658
	160	2000	10.4	98610	98660
	160	2500	12.9	419280	419288
	160	3000	15.4	98612	98662
	160	4000	20.4	419464	419488
	160	5000	25.4	419472	419496
160	6000	30.4	419480	419504	
Viton	160	150	1.1	98549	98599
	160	250	1.6	98601	98651
	160	500	2.9	98603	98653
	160	750	4.1	98605	98655
	160	1000	5.4	98607	98657
	160	1500	7.9	98609	98659
	160	2000	10.4	98611	98661
	160	2500	12.9	419281	419289
	160	3000	15.4	98613	98663
	160	4000	20.4	419465	419489
	160	5000	25.4	419473	419497
160	6000	30.4	419481	419505	

Table 6

Product ranges

200mm socketed pipe

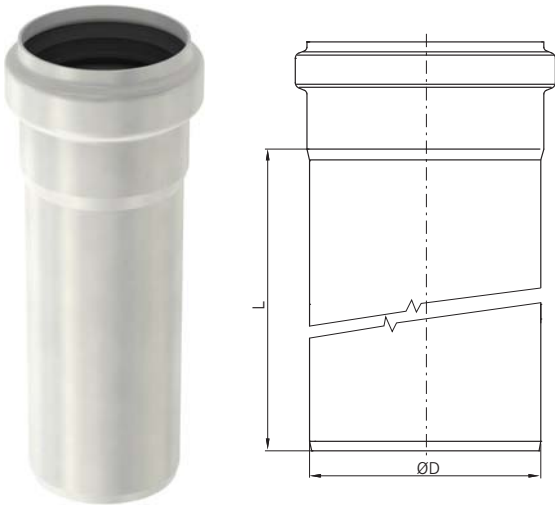

Seal material	D (mm)	Active length L (mm)	Weight (kg)	Part No 304	Part No 316
EPDM	200	500	4.5	419383	419384
	200	1000	8.3	419387	419388
	200	2000	15.8	419391	419392
	200	3000	23.2	419395	419396
Viton	200	500	4.5	419385	419386
	200	1000	8.3	419389	419390
	200	2000	15.8	419393	419394
	200	3000	23.2	419397	419398

Table 7

Product ranges

50mm double socketed pipe



Seal material	D (mm)	Active length L (mm)	Weight (kg)	Part No 304	Part No 316
EPDM	50	250	0.4	419554	419594
	50	500	0.7	419556	419596
	50	750	1.1	419558	419598
	50	1000	1.4	419560	419600
	50	1500	2.0	419562	419602
	50	2000	2.6	419564	419604
	50	3000	3.9	419566	419606
Viton	50	250	0.4	419555	419595
	50	500	0.7	419557	419597
	50	750	1.1	419559	419599
	50	1000	1.4	419561	419601
	50	1500	2.0	419563	419603
	50	2000	2.6	419565	419605
	50	3000	3.9	419567	419607

Table 8

Product ranges

75mm double socketed pipe

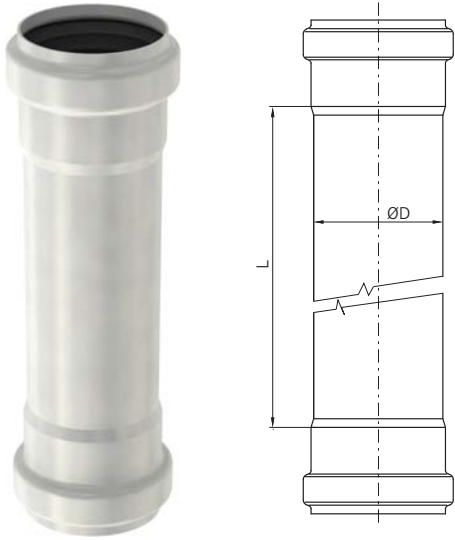

Seal material	D (mm)	Active length L (mm)	Weight (kg)	Part No 304	Part No 316
EPDM	75	250	0.7	419568	419608
	75	500	1.2	419570	419610
	75	750	1.6	419572	419612
	75	1000	2.1	419574	419614
	75	1500	3.0	419576	419616
	75	2000	4.0	419578	419618
	75	3000	5.8	419580	419620
Viton	75	250	0.7	419569	419609
	75	500	1.2	419571	419611
	75	750	1.6	419573	419613
	75	1000	2.1	419575	419615
	75	1500	3.0	419577	419617
	75	2000	4.0	419579	419619
	75	3000	5.8	419581	419621

Table 9

Product ranges

110mm double socketed pipe



Seal material	D (mm)	Active length L (mm)	Weight (kg)	Part No 304	Part No 316
EPDM	110	500	1.7	419582	419622
	110	750	2.4	419584	419624
	110	1000	3.0	419586	419626
	110	1500	4.4	419588	419628
	110	2000	5.7	419590	419630
	110	3000	8.4	419592	419632
Viton	110	500	1.7	419583	419623
	110	750	2.4	419585	419625
	110	1000	3.0	419587	419627
	110	1500	4.4	419589	419629
	110	2000	5.7	419591	419631
	110	3000	8.4	419593	419633

Table 10

Product ranges

125mm double socketed pipe



Seal material	D (mm)	Active length L (mm)	Weight (kg)	Part No 304	Part No 316
EPDM	125	500	1.7	419787	419799
	125	750	2.5	419789	419801
	125	1000	3.3	419791	419803
	125	1500	4.9	419793	419805
	125	2000	6.5	419795	419807
	125	3000	9.6	419797	419809
Viton	125	500	1.7	419788	419800
	125	750	2.5	419790	419802
	125	1000	3.3	419792	419804
	125	1500	4.9	419794	419806
	125	2000	6.5	419796	419808
	125	3000	9.6	419798	419810

Table 11



Product ranges

160mm double socketed pipe



Seal material	D (mm)	Active length L (mm)	Weight (kg)	Part No 304	Part No 316
EPDM	160	500	3.3	419634	419646
	160	750	4.5	419636	419648
	160	1000	5.8	419638	419650
	160	1500	8.2	419640	419652
	160	2000	10.7	419642	419654
	160	3000	15.7	419644	419656
Viton	160	500	3.3	419635	419647
	160	750	4.5	419637	419649
	160	1000	5.8	419639	419651
	160	1500	8.2	419641	419653
	160	2000	10.7	419643	419655
	160	3000	15.7	419645	419657

Table 12

Product ranges

200mm double socketed pipe

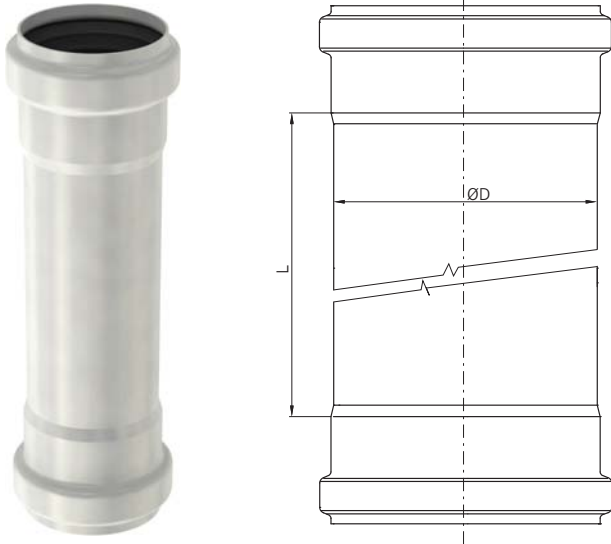

Seal material	D (mm)	Active length L (mm)	Weight (kg)	Part No 304	Part No 316
EPDM	200	500	5.0	419658	419659
	200	1000	8.6	419662	419663
	200	2000	15.9	419666	419667
	200	3000	23.1	419670	419671
Viton	200	500	5.0	419660	419661
	200	1000	8.6	419664	419665
	200	2000	15.9	419668	419669
	200	3000	23.1	419672	419673

Table 13



Product ranges

87.5° bend

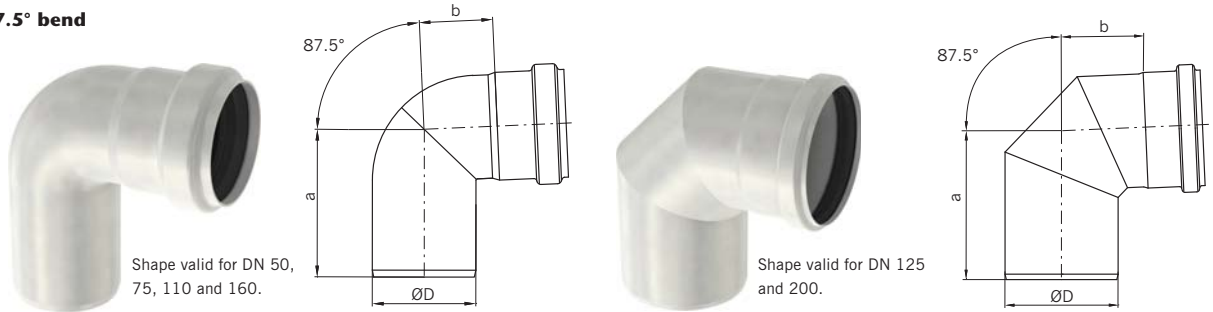

Seal material	D (mm)	a (mm)	b (mm)	Weight (kg)	Part No 304	Part No 316
EPDM	50	86	40	0.2	98700	98750
	75	107	53	0.4	98702	98752
	110	134	67	0.7	98704	98754
	125	161	93	0.8	419732	419734
	160	181	105	1.7	98706	98756
	200	215	129	3.9	419411	419413
Viton	50	86	40	0.2	98701	98751
	75	107	53	0.4	98703	98753
	110	134	67	0.7	98705	98755
	125	161	93	0.8	419733	419735
	160	181	105	1.7	98707	98757
	200	215	129	3.9	419412	419414

Table 14

45° bend

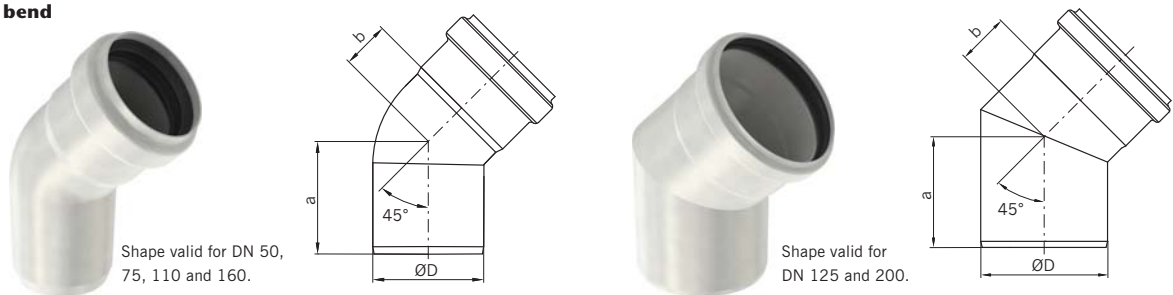

Seal material	D (mm)	a (mm)	b (mm)	Weight (kg)	Part No 304	Part No 316
EPDM	50	62	24	0.2	98708	98758
	75	76	32	0.3	98710	98760
	110	93	42	0.5	98712	98762
	125	110	50	0.6	419736	419738
	160	131	55	1.3	98714	98764
	200	152	60	2.7	419407	419409
Viton	50	62	24	0.2	98709	98759
	75	76	32	0.3	98711	98761
	110	93	42	0.5	98713	98763
	125	110	50	0.6	419737	419739
	160	131	55	1.3	98715	98765
	200	152	60	2.7	419408	419410

Table 15

Product ranges

30° bend

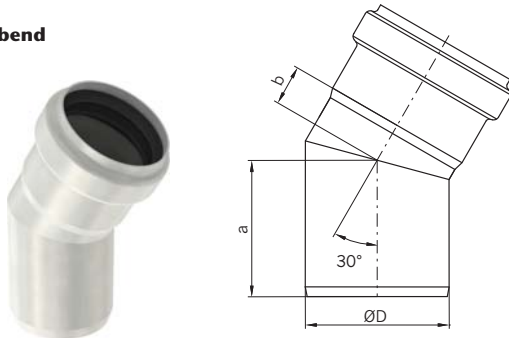

Seal material	D (mm)	a (mm)	b (mm)	Weight (kg)	Part No 304	Part No 316
EPDM	50	57	16	0.2	98716	98766
	75	71	21	0.3	98718	98768
	110	85	27	0.5	98720	98770
	125	98	28	0.6	419740	419742
	160	110	40	1.2	98722	98772
	200	137	45	2.3	419403	419405
Viton	50	57	16	0.2	98717	98767
	75	71	21	0.3	98719	98769
	110	85	27	0.5	98721	98771
	125	98	28	0.6	419741	419743
	160	110	40	1.2	98723	98773
	200	137	45	2.3	419404	419406

Table 16

15° bend

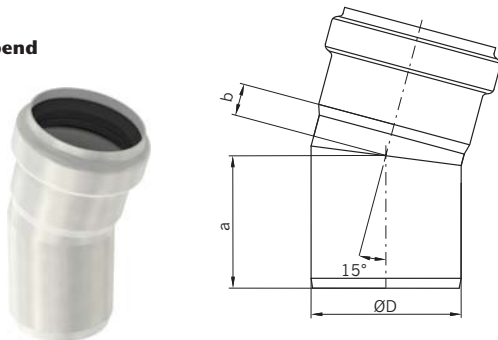

Seal material	D (mm)	a (mm)	b (mm)	Weight (kg)	Part No 304	Part No 316
EPDM	50	54	12	0.1	98724	98774
	75	66	16	0.3	98726	98776
	110	78	15	0.4	98728	98778
	125	84	19	0.5	419744	419746
	160	99	29	1.0	98730	98780
	200	123	31	1.9	419399	419401
Viton	50	54	12	0.1	98725	98775
	75	66	16	0.3	98727	98777
	110	78	15	0.4	98729	98779
	125	84	19	0.5	419745	419747
	160	99	29	1.0	98731	98781
	200	123	31	1.9	419400	419402

Table 17

Product ranges

87.5° long bend

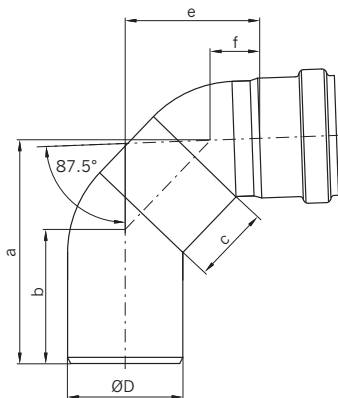

Seal material	D (mm)	a (mm)	b (mm)	c (mm)	e (mm)	f (mm)	Weight (kg)	Part No 304	Part No 316
EPDM	50	123	71	50	75	25	0.3	419146	419000
	75	146	87	50	88	32	0.5	419148	419002
	110	175	103	250	103	39	1.4	419150	419004
	160	222	126	250	183	92	2.2	419152	419144
Viton	50	123	71	50	75	25	0.3	419147	419001
	75	146	87	50	88	32	0.5	419149	419003
	110	175	103	250	103	39	1.4	419151	419005
	160	222	126	250	183	92	2.2	419153	419145

Table 18

1 x 92.5° tall bend

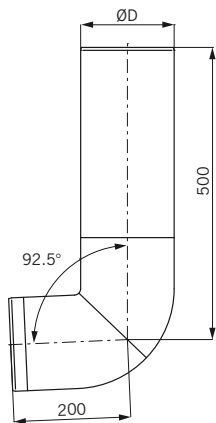

D (mm)	Weight (kg)	Part No 304	Part No 316
110	2.0	417056	417057
160	3.7	417058	417059

Table 19

Product ranges

2 x 46° tall bend

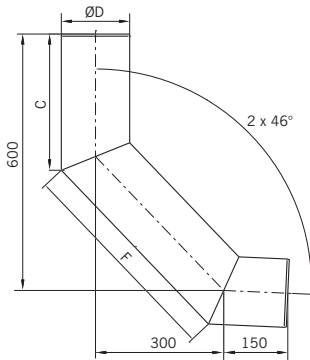

D (mm)	C (mm)	F (mm)	Weight (kg)	Part No 304	Part No 316
110	309	478	2.4	417060	417061
160	319	498	4.4	417062	417063

Table 20

87.5° single branch

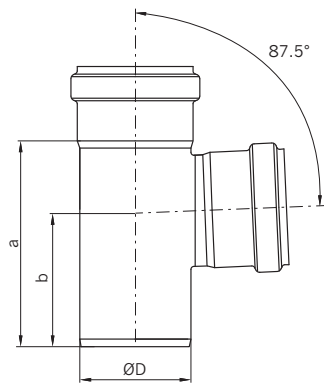

Seal material	D (mm)	a (mm)	b (mm)	Weight (kg)	Part No 304	Part No 316
EPDM	50	106	71	0.3	98732	98782
	75	139	90	0.5	98734	98784
	110	183	117	0.8	98736	98786
	125	220	135	0.9	419748	419750
	160	288	184	2.3	98738	98788
	200	333	206	4.5	419419	419421
Viton	50	106	71	0.3	98733	98783
	75	139	90	0.5	98735	98785
	110	183	117	0.8	98737	98787
	125	220	135	0.9	419749	419751
	160	288	184	2.3	98739	98789
	200	333	206	4.5	419420	419422

Table 21



Product ranges

89° single swept branch special

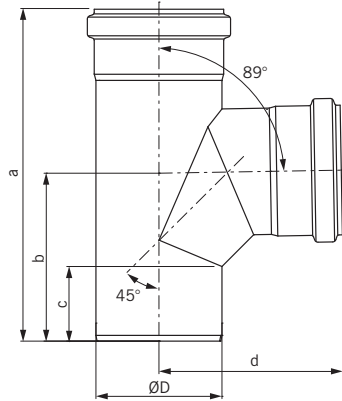

Seal material	D (mm)	a (mm)	b (mm)	c (mm)	d (mm)	Weight (kg)	Part No 304
EPDM	110	295	148	76	160	1.1	415111
	75	229	125	68	134	0.6	415112
	50	170	88	48	100	0.3	415113

Table 22

45° single branch

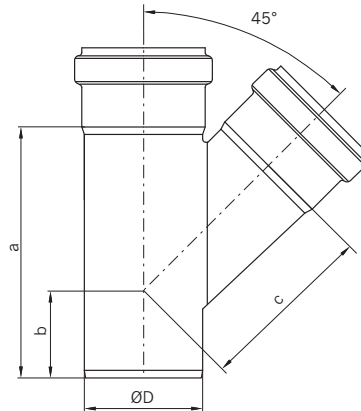

Seal material	D (mm)	a (mm)	b (mm)	c (mm)	Weight (kg)	Part No 304	Part No 316
EPDM	50	128	57	76	0.3	98748	98798
	75	179	74	110	0.5	98800	98850
	110	233	88	149	1.0	98802	98852
	125	273	103	170	1.1	419760	419762
	160	332	119	222	2.6	98804	98854
	200	415	151	274	5.7	419427	419429
Viton	50	128	57	76	0.3	98749	98799
	75	179	74	110	0.5	98801	98851
	110	233	88	149	1.0	98803	98853
	125	273	103	170	1.1	419761	419763
	160	332	119	222	2.6	98805	98855
	200	415	151	274	5.7	419428	419430

Table 23

Product ranges

87.5° double branch

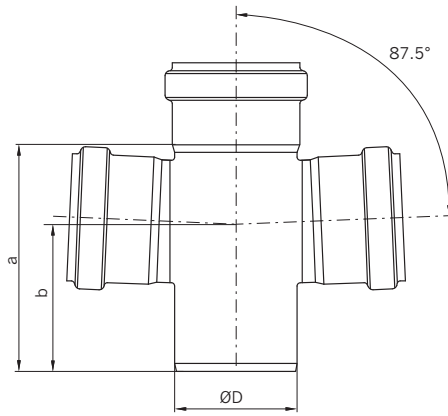

Seal material	D (mm)	a (mm)	b (mm)	Weight (kg)	Part No 304	Part No 316
EPDM	50	106	71	0.3	98740	98790
	75	139	90	0.6	98742	98792
	110	183	117	0.9	98744	98794
	160	288	184	2.7	98746	98796
Viton	50	106	71	0.3	98741	98791
	75	139	90	0.6	98743	98793
	110	183	117	0.9	98745	98795
	160	288	184	2.7	98747	98797

Table 24

89° double swept branch special

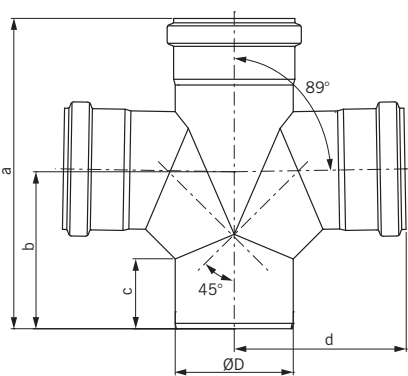

Seal material	D (mm)	a (mm)	b (mm)	c (mm)	d (mm)	Weight (kg)	Part No 304
EPDM	110	295	148	76	160	1.4	415108
	75	229	125	68	134	0.8	415109
	50	170	88	48	100	0.4	415110

Table 25



Product ranges

45° double branch

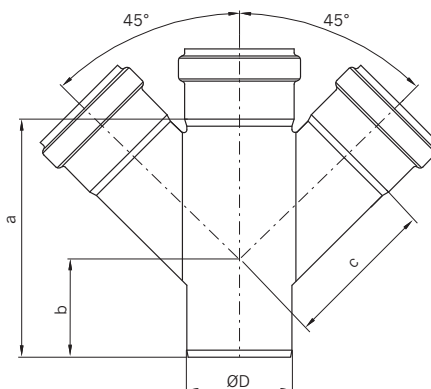

Seal material	D (mm)	a (mm)	b (mm)	c (mm)	Weight (kg)	Part No 304	Part No 316
EPDM	50	128	57	76	0.4	98806	98856
	75	179	74	110	0.7	98808	98858
	110	233	88	149	1.2	98810	98860
	160	332	184	222	3.5	98812	98862
Viton	50	128	57	76	0.4	98807	98857
	75	179	74	110	0.7	98809	98859
	110	233	88	149	1.2	98811	98861
	160	332	184	222	3.5	98813	98863

Table 26

87.5° corner branch

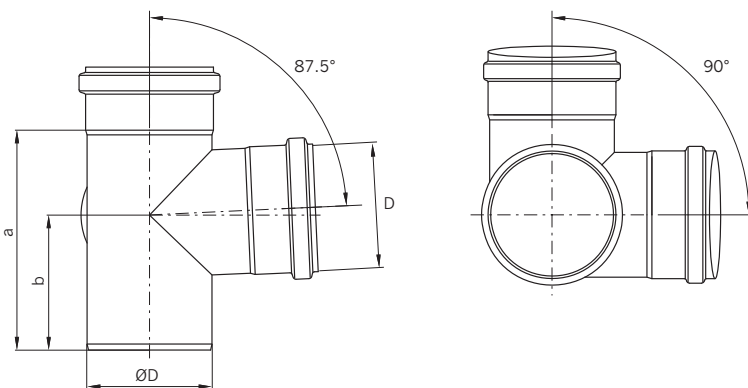

Seal material	D (mm)	a (mm)	b (mm)	Weight (kg)	Part No 304	Part No 316
EPDM	50	106	71	0.4	419162	419210
	75	139	90	0.7	419164	419212
	110	183	117	1.1	419166	419214
	125	220	135	1.6	417020	417021
	160	288	184	2.9	419168	419216
Viton	50	106	71	0.4	419163	419211
	75	139	90	0.7	419165	419213
	110	183	117	1.1	419167	419215
	125	220	135	1.6	417054	417055
	160	288	184	2.9	419169	419217

Table 27

Product ranges

87.5° single branch reduction

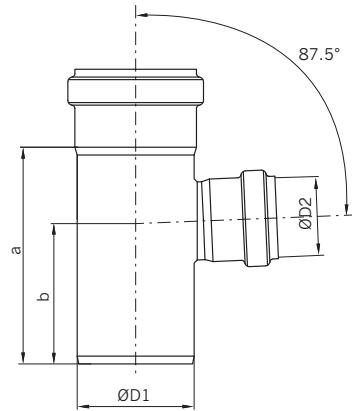

Seal material	D1 (mm)	D2 (mm)	a (mm)	b (mm)	Weight (kg)	Part No 304	Part No 316
EPDM	75	50	139	90	0.3	98928	98930
	110	50	183	117	0.5	98932	98934
	110	75	183	117	0.8	98936	98938
	125	75	187	110	0.9	419752	419754
	125	110	205	127	0.9	419756	419758
	160	110	288	184	2.3	400691	400693
Viton	200	160	293	186	3.7	419415	419417
	75	50	139	90	0.3	98929	98931
	110	50	183	117	0.5	98933	98935
	110	75	183	117	0.8	98937	98939
	125	75	187	110	0.9	419753	419755
	125	110	205	127	0.9	419757	419759
	160	110	288	184	2.3	400692	400694
200	160	293	186	3.7	419416	419418	

Table 28

89° single swept branch reduction special

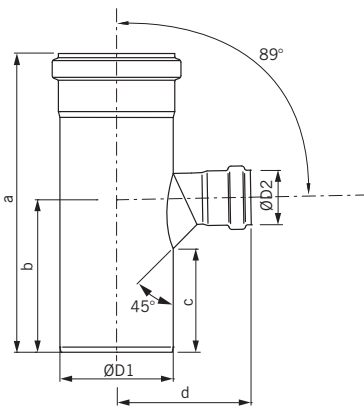

Seal material	D1 (mm)	D2 (mm)	a (mm)	b (mm)	c (mm)	d (mm)	Weight (kg)	Part No 304
EPDM	110	50	295	148	104	135	0.9	415106
	110	75	295	148	81	143	1.0	415107

Table 29



Product ranges

45° single branch reduction

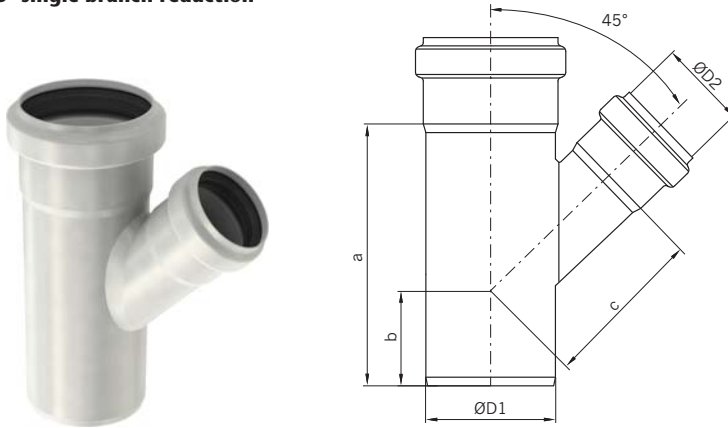

Seal material	D1 (mm)	D2 (mm)	a (mm)	b (mm)	c (mm)	Weight (kg)	Part No 304	Part No 316
EPDM	75	50	144	56	94	0.3	400661	400663
	110	50	147	42	119	0.5	400665	400667
	110	75	182	60	135	1.0	400669	400671
	125	75	200	65	141	1.1	419764	419766
	125	110	250	90	160	1.1	419768	419770
	160	110	332	119	191	2.6	400699	400701
	200	160	359	123	250	4.7	419423	419425
Viton	75	50	144	56	94	0.3	400662	400664
	110	50	147	42	119	0.5	400666	400668
	110	75	182	60	135	1.0	400670	400672
	125	75	200	65	141	1.1	419765	419767
	125	110	250	90	160	1.1	419769	419771
	160	110	332	119	191	2.6	400700	400702
	200	160	359	123	250	4.7	419424	419426

Table 30

Product ranges

87.5° double branch reduction

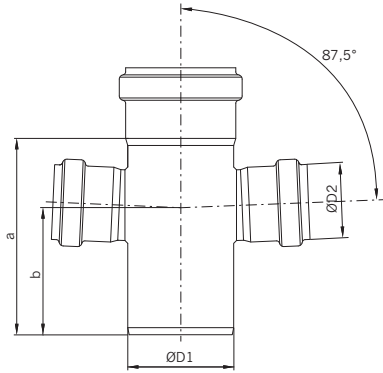

Seal material	D (mm)	D2 (mm)	a (mm)	b (mm)	Weight (kg)	Part No 304	Part No 316
EPDM	75	50	139	90	0.3	98940	98942
	110	50	183	117	0.6	98944	98946
	110	75	183	117	0.9	98900	98902
	160	110	288	184	2.7	400695	400697
Viton	75	50	139	90	0.3	98941	98943
	110	50	183	117	0.6	98945	98947
	110	75	183	117	0.9	98901	98903
	160	110	288	184	2.7	400696	400698

Table 31

89° double swept branch reduction special

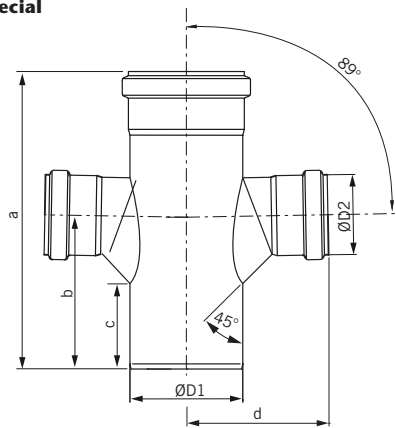

Seal material	D1 (mm)	D2 (mm)	a (mm)	b (mm)	c (mm)	d (mm)	Weight (kg)	Part No 304
EPDM	110	75	295	148	81	143	1.1	415104
	110	50	295	148	104	135	1.0	415105

Table 32



Product ranges

45° double branch reduction

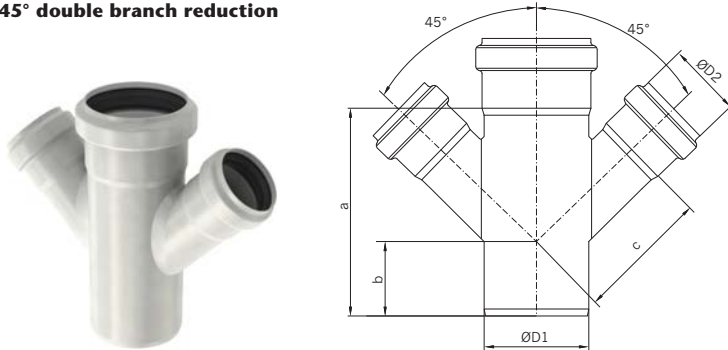

Seal material	D1 (mm)	D2 (mm)	a (mm)	b (mm)	c (mm)	Weight (kg)	Part No 304	Part No 316
EPDM	75	50	144	56	94	0.4	400673	400675
	110	50	147	42	119	0.7	400677	400679
	110	75	182	60	135	1.2	400681	400683
	160	110	332	119	190	3.5	400703	400705
Viton	75	50	144	56	94	0.4	400674	400676
	110	50	147	42	119	0.7	400678	400680
	110	75	182	60	135	1.2	400682	400684
	160	110	332	119	190	3.5	400704	400706

Table 33

87.5° swept single branch

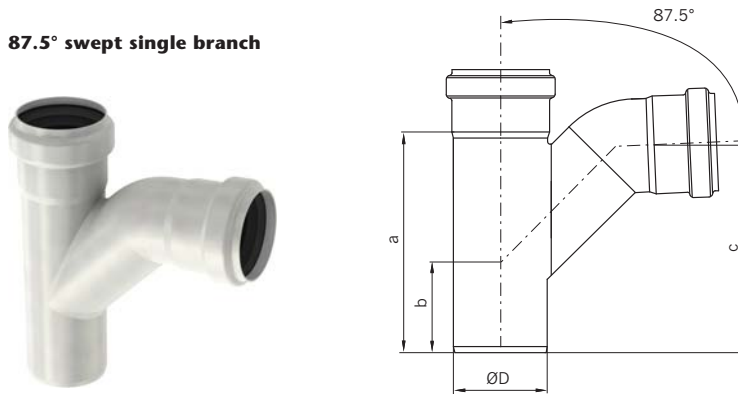

Seal material	D (mm)	a (mm)	b (mm)	c (mm)	Weight (kg)	Part No 304	Part No 316
EPDM	50	128	57	117	0.3	98814	98864
	75	179	74	157	0.6	98816	98866
	110	233	88	209	1.1	98818	98868
	160	332	184	302	2.8	98820	98870
Viton	50	128	57	117	0.3	98815	98865
	75	179	74	157	0.6	98817	98867
	110	233	88	209	1.1	98819	98869
	160	332	184	302	2.8	98821	98871

Table 34

Product ranges

"P" trap

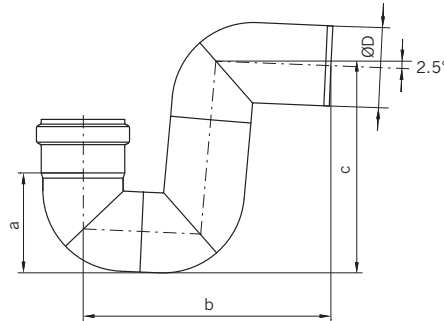

Seal material	D (mm)	a (mm)	b (mm)	c (mm)	Weight (kg)	Part No 304	Part No 316
EPDM	50	68	187	149	0.5	98822	98872
	75	94	232	193	0.7	98824	98874
	110	132	300	254	1.3	98826	98876
	160	190	403	347	3.3	98828	98878
Viton	50	68	187	149	0.5	98823	98873
	75	94	232	193	0.7	98825	98875
	110	132	300	254	1.3	98827	98877
	160	190	403	347	3.3	98829	98879

Table 35



Product ranges

Straight coupling

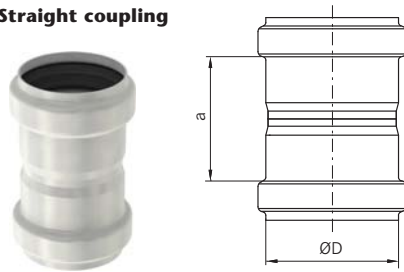

Seal material	D (mm)	a (mm)	Weight (kg)	Part No 304	Part No 316
EPDM	50	54	0.1	98920	98970
	75	75	0.2	98922	98972
	110	84	0.4	98924	98974
	125	140	0.4	419813	419815
	160	110	0.8	98926	98976
	200	136	1.8	419431	419433
Viton	50	54	0.1	98921	98971
	75	75	0.2	98923	98973
	110	84	0.4	98925	98975
	125	140	0.4	419814	419816
	160	110	0.8	98927	98977
	200	136	1.8	419432	419434

Table 36

Repair coupling

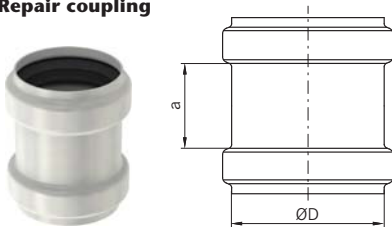

Seal material	D (mm)	a (mm)	Weight (kg)	Part No 304	Part No 316
EPDM	50	44	0.1	98830	98880
	75	46	0.2	98832	98882
	110	52	0.3	98834	98884
	125	70	0.3	419772	419774
	160	76	0.7	98836	98886
	200	100	1.5	419435	419437
Viton	50	44	0.1	98831	98881
	75	46	0.2	98833	98883
	110	52	0.3	98835	98885
	125	70	0.3	419773	419775
	160	76	0.7	98837	98887
	200	100	1.5	419436	419438

Table 37

Note: Repair couplings are used to aid a convenient repair to a damaged in-situ pipe. Unlike the standard straight coupling, there is no central registration to limit the insertion depth of the pipe. The repair coupling slides completely over a pipe joint and simply re-positioned to bridge the required pipe joint. **Installation tip:** Mark the final position of the repair coupling on the installed pipe system to ensure the coupling seals are positioned symmetrically about the pipe joint.

Product ranges

Expansion socket

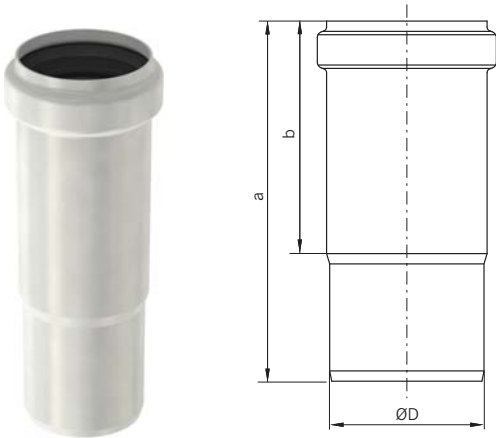

Seal material	D (mm)	a (mm)	b (mm)	Weight (kg)	Part No 304	Part No 316
EPDM	50	159	102	0.2	98664	98666
	75	175	113	0.3	98668	98670
	110	200	121	0.5	98672	98674
	125	250	165	0.6	419776	419778
	160	292	170	1.4	98676	98678
Viton	50	159	102	0.2	98665	98667
	75	175	113	0.3	98669	98671
	110	200	121	0.5	98673	98675
	125	250	165	0.6	419777	419779
	160	292	170	1.4	98677	98679

Table 38

Note: Expansion socket is generally used in conjunction with a branch unit when adding a branch into an existing pipe run.



Product ranges

Eccentric increaser coupling

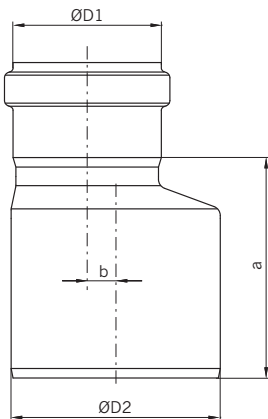

Seal material	D1 (mm)	D2 (mm)	a (mm)	b (mm)	Weight (kg)	Part No 316
EPDM	50	75	88	7	0.3	98892
	50	110	103	25	0.4	98978
	75	110	116	15	0.5	98894
	110	160	136	22	1.1	98896
Viton	50	75	88	7	0.3	98893
	50	110	103	25	0.4	98979
	75	110	116	15	0.5	98895
	110	160	136	22	1.1	98897

Table 39

Concentric increaser coupling

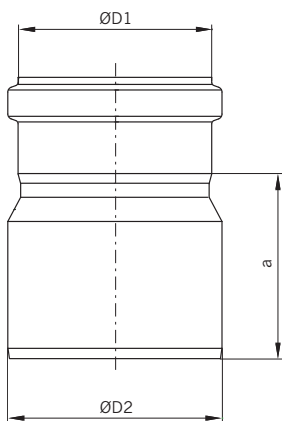

Seal material	D1 (mm)	D2 (mm)	a (mm)	b (mm)	Weight (kg)	Part No 316
EPDM	110	125	107	0	0.6	419780
	125	160	113	0	1.2	419811
	160	200	170	0	1.8	419441
Viton	110	125	107	0	0.6	419781
	125	160	113	0	1.2	419812
	160	200	170	0	1.8	419442

Table 40

Product ranges

Increaser connector

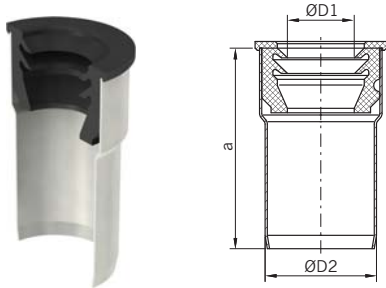

Seal material	D1 (mm)	D2 (mm)	a (mm)	Weight (kg)	Part No 316
NBR	32	50	90	0.2	419373
NBR	40	50	90	0.2	419374

Table 41

Connector with internal screw thread and spigot

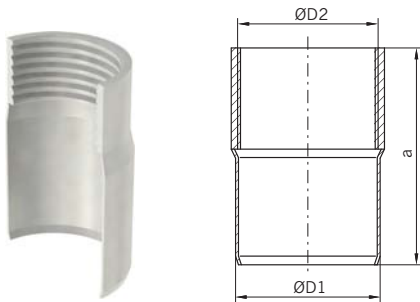

D1 (mm)	D2	a (mm)	Weight (kg)	Part No 316
50	Rp 1¼"	72	0.2	98956
50	Rp 1½"	75	0.3	98957
50	Rp 2"	80	0.3	98958

Table 42

Connector with external screw thread and spigot

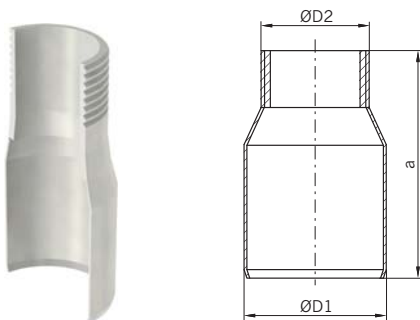

D1 (mm)	D2	a (mm)	Weight (kg)	Part No 316
50	Rp 1¼"	100	0.2	419330
50	Rp 1½"	100	0.3	419331
50	Rp 2"	100	0.3	419332

Table 43

Product ranges

Connector with socket and internal screw thread

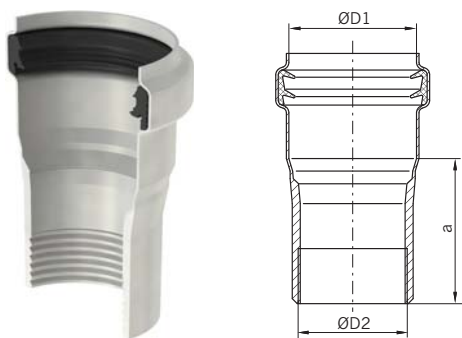

Seal material	D1 (mm)	D2	a (mm)	Weight (kg)	Part No 316
EPDM	50	R 1¼"	58	0.2	419333
	50	R 1½"	58	0.3	419335
	50	R 2"	58	0.3	419337
Viton	50	R 1¼"	58	0.2	419334
	50	R 1½"	58	0.3	419336
	50	R 2"	58	0.3	419338

Table 44

Connector with socket and external screw thread

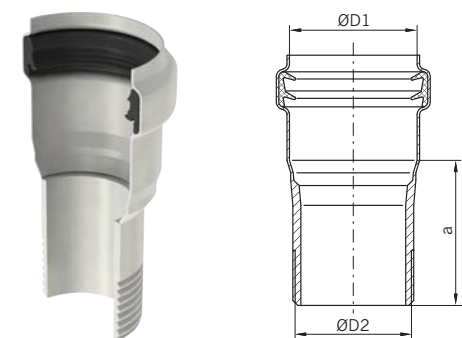

Seal material	D1 (mm)	D2	a (mm)	Weight (kg)	Part No 316
EPDM	50	R 1¼"	58	0.2	419250
	50	R 1½"	58	0.3	419252
	50	R 2"	58	0.3	419254
Viton	50	R 1¼"	58	0.2	419251
	50	R 1½"	58	0.3	419253
	50	R 2"	58	0.3	419255

Table 45

Product ranges

Connector with socket and flange

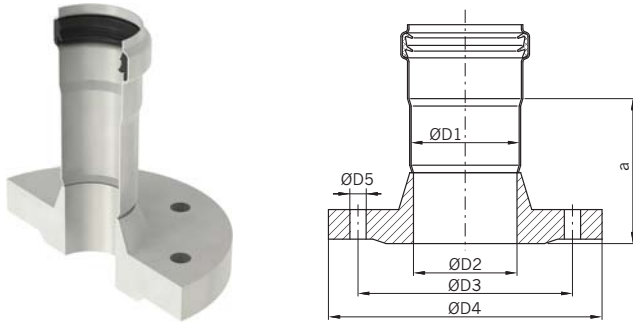

Seal material	D1 (mm)	D2 (mm)	D3 (mm)	D4 (mm)	n × D5 (mm)	a (mm)	Weight (kg)	Part No 316
EPDM	50	DN 40	110	150	4 × 18	100	2.3	419256
	50	DN 50	125	165	4 × 18	100	2.7	419258
	75	DN 65	145	185	4 × 18	100	3.4	419260
	110	DN 100	180	220	8 × 18	100	4.9	419262
	200	DN 200	295	340	12 × 22	102	12.0	419514
Viton	50	DN 40	110	150	4 × 18	100	2.3	419257
	50	DN 50	125	165	4 × 18	100	2.7	419259
	75	DN 65	145	185	4 × 18	100	3.4	419261
	110	DN 100	180	220	8 × 18	100	4.9	419263
	200	DN 200	295	340	12 × 22	102	12.0	419515

Table 46

Note: Flange PN16 to DIN 2633. Flanges to PN6 and PN10 available on request.

Connector with spigot and flange

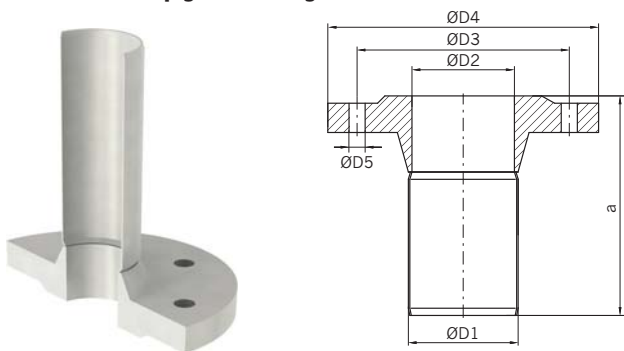

D1 (mm)	D2 (mm)	D3 (mm)	D4 (mm)	n × D5 (mm)	a (mm)	Weight (kg)	Part No 316
50	DN 40	110	150	4 × 18	192	2.3	419264
50	DN 50	125	165	4 × 18	192	2.7	419265
75	DN 65	145	185	4 × 18	245	3.4	419266
110	DN 100	180	220	8 × 18	259	4.9	419267
160	DN 150	240	285	8 × 22	200	8.5	419540
200	DN 200	295	240	12 × 22	240	12.3	419541

Table 47

Note: Flange PN16 to DIN 2633. Flanges to PN6 and PN10 available on request.

Product ranges

Connector cast iron spigot → ACO PIPE® socket

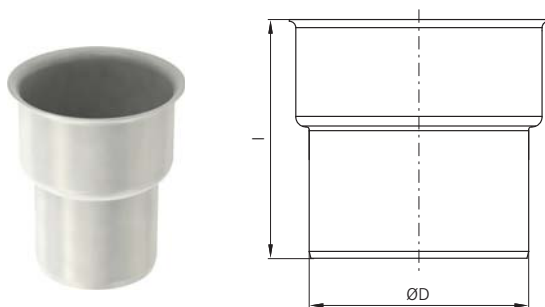

D (mm)	l (mm)	Weight (kg)	Part No 316
75	121	0.4	98904
110	137	0.6	98906
160	174	1.0	98905

Table 48

Note: Connector is not supplied with seals. Select the required reduction seal from page 43, tables 55, 56 and 57.

Access unit

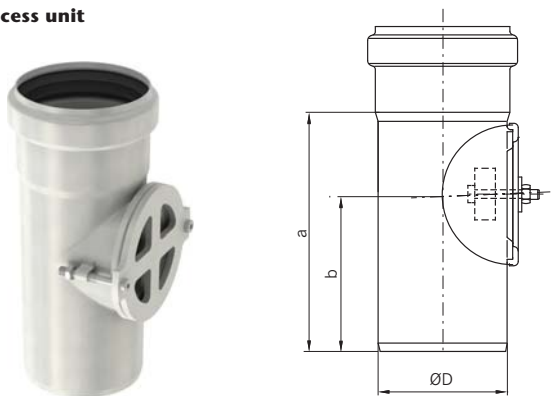

Seal material	D (mm)	a (mm)	b (mm)	Weight (kg)	Part No AISI 304	Part No 316
EPDM	75	139	90	0.5	98913	98963
	110	183	117	0.8	98915	98965
	125	210	135	0.9	419783	419785
	160	288	184	2.3	98917	98967
	200	293	186	3.7	419676	419678
Viton	75	139	90	0.5	98914	98964
	110	183	117	0.8	98916	98966
	125	210	135	0.9	419784	419786
	160	288	184	2.3	98918	98968
	200	293	186	3.7	419677	419679

Table 49

Product ranges

Rat-stop pipe

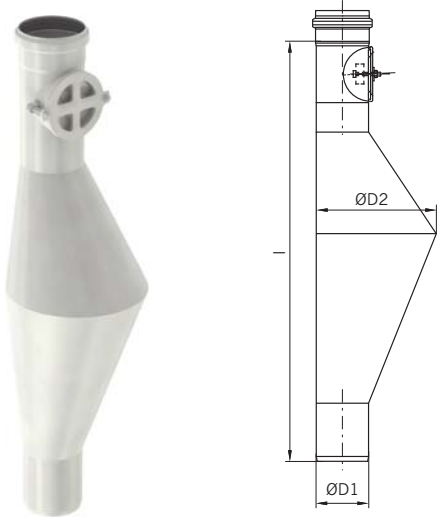

Seal material	D1 (mm)	D2 (mm)	l (mm)	Weight (kg)	Part No 304	Part No 316
EPDM	110	250	864	3.8	419268	419270
Viton	110	250	864	3.8	419269	419271

Table 50

Socket plug (no clamp)

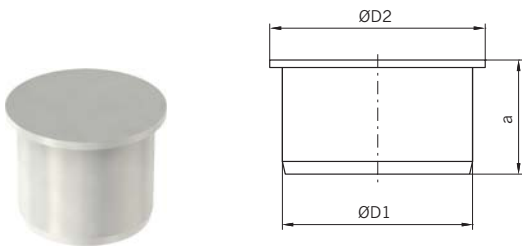

D1 (mm)	D2 (mm)	a (mm)	Weight (kg)	Part No 316
50	58	45	0.1	98888
75	85	45	0.3	98889
110	120	45	0.5	98890
125	135	50	0.6	419782
160	170	50	0.5	98891
200	210	50	1.0	98994

Table 51

Product ranges

Socket plug (with clamp)

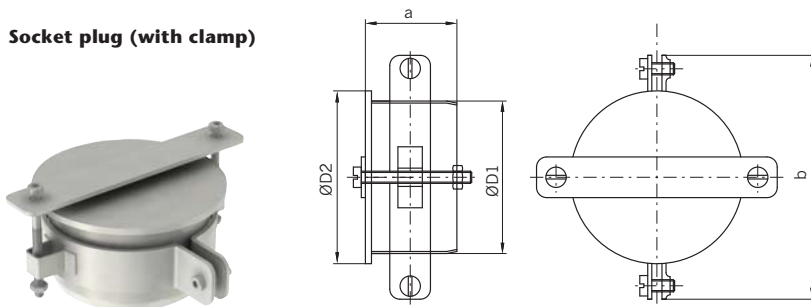

D1 (mm)	D2 (mm)	a (mm)	b (mm)	Weight (kg)	Part No 316
50	58	45	88	0.4	419138
75	85	45	120	0.6	419139
110	120	45	167	0.8	419140
160	170	50	214	1.1	419141

Table 52

Socket clamp

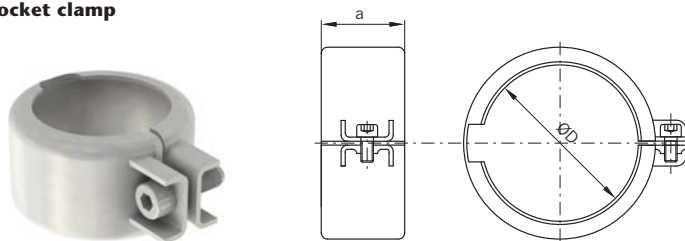

D (mm)	a (mm)	Weight (kg)	Part No 316
50	40	0.1	419134
75	40	0.2	419135
110	43	0.3	419136
160	43	0.4	419137

Table 53

Note: Socket clamp can be used to add joint security for increased internal pressure as shown on page 49 and/or for electrical earthing continuity.

Vent cowl

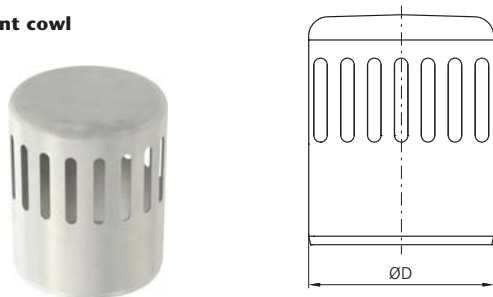

D (mm)	Weight (kg)	Part No 316
110	0.4	98962

Table 54

Product ranges

Prefabricated manifolds

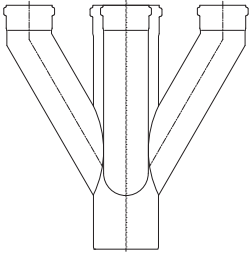

ACO Building Drainage can design and manufacture bespoke manifolds to suit any application. Please contact our Bespoke Department on 01462 816666 for further information.

Reduction sealing cast Iron spigot → ACO PIPE® socket

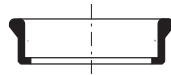

Cast iron spigot (mm)	Weight (kg)	Part No EPDM
75 / DN 70	0.06	400580
110 / DN 100	0.10	400581
160 / DN 150	0.14	400582

Table 55

Reduction sealing ACO PIPE® spigot → cast iron socket



Cast iron spigot (mm)	Weight (kg)	Part No EPDM
75 / DN 70	0.05	400586
110 / DN 100	0.08	400587
160 / DN 150	0.12	400588

Table 56

Reduction sealing set for cast iron

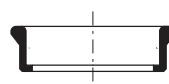
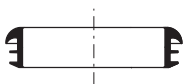

Cast iron spigot (mm)	Weight (kg)	Part No EPDM
75 / DN 70	0.11	419370
110 / DN 100	0.18	419371
160 / DN 150	0.26	419372

Table 57

Set of reduction sealings cast iron spigot → ACO PIPE® socket and ACO PIPE® spigot → cast iron

Product ranges

Socket clamp



D (mm)	Weight (kg)	Part No EPDM	Part No Viton
50	0.01	98400	98404
75	0.02	98401	98405
110	0.05	98402	98406
125	0.06	419453	419454
160	0.08	98403	98407
200	0.10	98433	98437

Table 58

Note: Spare ACO PIPE® seals in EPDM and Viton® grades are available for all pipe sizes. All seals incorporate the unique ACO PIPE® double lip seal arrangement for increased reliability and security. Both seal materials are mechanically interchangeable thereby facilitating easy on-site upgrade from EPDM to Viton®, for example. For seal installation instructions, refer to the Appendices. To aid identification, the seals are colour coded as follows: EPDM seals are BLACK. Viton® seals are GREEN.

ACO Universal lubricant



Weight (kg)	Part No
0.15	E80350000

Table 59

ACO Universal lubricant in bucket 1kg

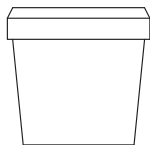

Weight (kg)	Part No
1.00	E80350001

Table 60

Fixing plate

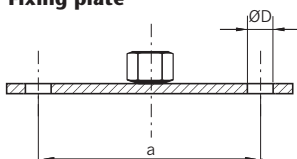

D (mm)	a (mm)	Weight (kg)	Part No Galvanised steel	Part No 316
8.4	70	0.05	400525	400521

Table 61

Product ranges

Support bracket with rubber infill

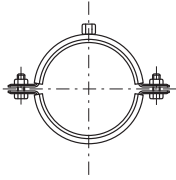

D (mm)	Weight (kg)	Part No Galvanised steel	Part No 316
50	0.14	400533	400529
75	0.23	400534	400530
110	0.33	400535	400531
125	0.36	419854	419855
160	0.39	400536	400532
200	0.44	419451	419675

Table 62

Support bracket with rubber infill and stirrup

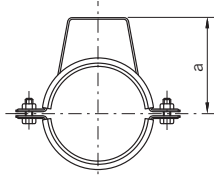

D (mm)	a (mm)	Weight (kg)	Part No Galvanised steel	Part No 316
50	56	0.18	400541	400537
75	80	0.28	400542	400538
110	116	0.41	400543	400539
160	166	0.48	400544	400540

Table 63

Support bracket with rubber infill and key

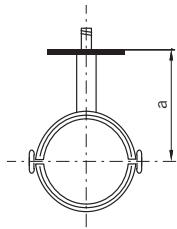

D (mm)	a (mm)	Weight (kg)	Part No Galvanised steel	Part No 316
50	120	0.16	400549	400545
75	133	0.26	400550	400546
110	150	0.38	400551	400547
160	175	0.44	400552	400548

Table 64



Product ranges

Threaded support pole M8

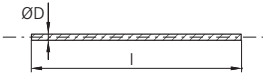

D (mm)	a (mm)	Weight (kg)	Part No Galvanised steel	Part No 316
M8	1000	0.39	400557	400553
M8	90	0.03	400558	400554
M8	40	0.016	400559	400555

Table 65

Set for axial fixing

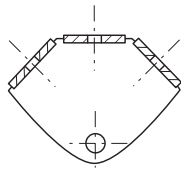

D	Weight (kg)	Part No EPDM
0.11	400565	400561

Table 66

Note: Six M8 nuts included.

ACO PIPE® cutter 50–110mm - manually operated



Note	Weight (kg)	Part No
In plastic case, including integrated pipe holder	3.50	419363

Table 67

Replacement discs for ACO PIPE® cutters

Note	Weight (kg)	Part No
for cutter 419363	0.005	419365

Table 68

Note: Minimum order quantity – 10 pcs.

Replacement cutting discs for ACO PIPE® cutter

Note	Weight (kg)	Part No
for cutter 400738 and 419364	0.005	400578

Table 69

Note: Minimum order quantity – 10 pcs..

Product ranges

ACO PIPE® manual cutter

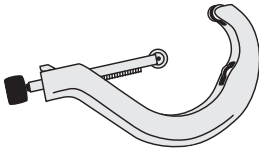

D (mm)	Weight (kg)	Part No
50-110	1.0	419364
110-160	2.0	400738

Table 70

Note: While purchasing ACO PIPE® manual cutter it is necessary to order ACO PIPE® holder for manual cutting.

ACO PIPE® holder for manual cutting

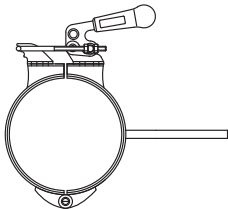

D (mm)	Weight (kg)	Part No
125	3.5	419857
160	4.0	400742

Table 71

Note: While ordering ACO PIPE® holder for manual cutting it is recommended to order ACO PIPE® cutter for manual cutting.

Pipe marking kit*

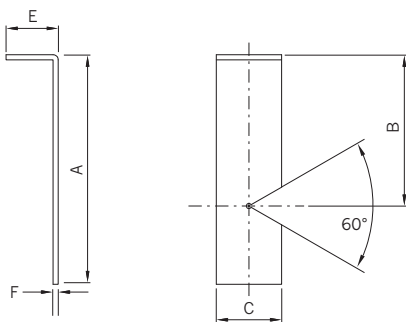

Part No	D (mm)	A (mm)	B (mm)	C (mm)	E (mm)	F (mm)	Weight (kg)
417064	50	78	48	25	20	2	0.35
	75	88	58	25	20	2	0.35
	110	93	63	25	20	2	0.35
	125	99	69	25	20	2	0.35
	160	107	77	25	20	2	0.35
	200	120	90	25	20	2	0.35

Table 72

***Note:** Pipe marking kit allows installer to conveniently and quickly mark pipes to ensure reliable visual insertion depth.



Flow rates and operating pressure

Full bore flow rate tables for varying gradients

For rainwater/storm drainage applications

Flow rates based on Colebrook-White formula.

Roughness Coefficient $k_s = 0.6\text{mm}$ (calculations uses internal diameters for pipes).

Gradient (%)	Pipe Ø 50mm		Pipe Ø 75mm		Pipe Ø 110mm		Pipe Ø 125mm		Pipe Ø 160mm		Pipe Ø 200mm	
	Flow rate Q (l/s)	Velocity v (m/s)	Flow rate Q (l/s)	Velocity v (m/s)	Flow rate Q (l/s)	Velocity v (m/s)	Flow rate Q (l/s)	Velocity v (m/s)	Flow rate Q (l/s)	Velocity v (m/s)	Flow rate Q (l/s)	Velocity v (m/s)
10.0	2.74	1.52	8.40	2.01	23.81	2.60	33.61	2.83	64.15	3.31	116.89	3.83
7.5	2.38	1.31	7.28	1.74	20.62	2.25	29.11	2.45	55.56	2.87	101.22	3.32
5.0	1.94	1.07	5.94	1.42	16.83	1.84	23.77	2.00	45.36	2.34	82.65	2.71
4.5	1.84	1.02	5.64	1.35	15.97	1.74	22.55	1.90	43.03	2.22	78.40	2.57
4.0	1.73	0.96	5.31	1.27	15.06	1.64	21.26	1.79	40.57	2.10	73.92	2.43
3.5	1.62	0.90	4.97	1.19	14.08	1.54	19.88	1.67	37.95	1.96	69.14	2.27
3.0	1.50	0.83	4.60	1.10	13.04	1.42	18.41	1.55	35.13	1.81	64.01	2.10
2.5	1.37	0.76	4.20	1.00	11.90	1.30	16.80	1.41	32.07	1.66	58.43	1.92
2.0	1.23	0.68	3.76	0.90	10.64	1.16	15.03	1.26	28.68	1.48	52.26	1.71
1.5	1.06	0.59	3.25	0.78	9.22	1.01	13.01	1.10	24.84	1.28	45.26	1.48
1.0	0.87	0.48	2.66	0.63	7.53	0.82	10.63	0.89	20.28	1.05	36.95	1.21

Table 73

The flow rates shown in the table 73 assume a free outlet from the pipe. For installations without a free outlet, the flow rate will be affected by the downstream throttle.

For shallow gradients, the Colebrook-White formula underestimates flow rates (because when gradient tends towards zero %, velocity also tends to zero). For level or nearly level installations (slope < 1 %), spatially varied flow tables should be used; refer to the table 75.

For soil/foul water drainage applications

Flow rates based on Colebrook-White formula.

Roughness Coefficient $k_s = 0.6\text{mm}$ (calculations uses internal diameters for pipes).

Gradient (%)	Pipe Ø 50mm		Pipe Ø 75mm		Pipe Ø 110mm		Pipe Ø 125mm		Pipe Ø 160mm		Pipe Ø 200mm	
	Flow rate Q (l/s)	Velocity v (m/s)	Flow rate Q (l/s)	Velocity v (m/s)	Flow rate Q (l/s)	Velocity v (m/s)	Flow rate Q (l/s)	Velocity v (m/s)	Flow rate Q (l/s)	Velocity v (m/s)	Flow rate Q (l/s)	Velocity v (m/s)
10.0	2.30	1.27	7.14	1.71	20.45	2.23	28.97	2.44	55.61	2.87	101.81	3.34
7.5	1.99	1.10	6.19	1.48	17.71	1.93	25.09	2.11	48.16	2.49	88.17	2.89
5.0	1.63	0.90	5.05	1.21	14.46	1.58	20.49	1.72	39.32	2.03	71.99	2.36
4.5	1.54	0.85	4.79	1.14	13.72	1.50	19.43	1.64	37.30	1.93	68.30	2.24
4.0	1.46	0.80	4.52	1.08	12.94	1.41	18.32	1.54	35.17	1.82	64.39	2.11
3.5	1.36	0.75	4.23	1.01	12.10	1.32	17.14	1.44	32.90	1.70	60.23	1.98
3.0	1.26	0.70	3.91	0.93	11.20	1.22	15.87	1.34	30.46	1.57	55.76	1.83
2.5	1.15	0.64	3.57	0.85	10.23	1.12	14.49	1.22	27.80	1.44	50.90	1.67
2.0	1.03	0.57	3.19	0.76	9.15	1.00	12.96	1.09	24.87	1.28	45.53	1.49
1.5	0.89	0.49	2.77	0.66	7.92	0.86	11.22	0.94	21.53	1.11	39.43	1.29
1.0	0.73	0.40	2.26	0.54	6.47	0.71	9.16	0.77	17.58	0.91	32.19	1.06

Table 74

The flow rates shown in the table 74 assume a free outlet from the pipe. For installations without a free outlet, the flow rate will be affected by the downstream throttle.

For shallow gradients, the Colebrook-White formula underestimates flow rates (because when gradient tends towards zero %, velocity also tends to zero). For level or nearly level installations (slope < 1 %), spatially varied flow tables should be used; refer to the table 75.



Flow rates and operating pressure

Full bore flow rate tables for varying gradients

Flow rates based on spatially-varied flow formula for steady non-uniform flow

Strickler Coefficient = 90

Pipe diameter (mm)	Length (m)	Gradient			
		0.0% Flow rate Q (l/s)	0.25% Flow rate Q (l/s)	0.5% Flow rate Q (l/s)	0.75% Flow rate Q (l/s)
50	5	0.40	0.57	0.75	0.92
50	10	0.30	0.54	0.75	0.92
50	15	0.26	0.53	0.75	0.92
50	20	0.23	0.53	0.75	0.92
75	5	1.45	1.75	2.40	2.90
75	10	1.10	1.72	2.35	2.90
75	15	0.95	1.70	2.35	2.90
75	20	0.85	1.70	2.35	2.90
110	5	4.50	5.55	6.75	8.15
110	10	3.60	5.05	6.60	8.15
110	15	3.20	4.90	6.50	8.15
110	20	2.80	4.80	6.50	8.15
125	5	6.45	7.90	9.60	11.45
125	10	5.20	7.25	9.50	11.45
125	15	4.55	7.00	9.50	11.45
125	20	4.10	6.85	9.50	11.45
160	5	13.00	15.40	18.60	21.20
160	10	10.90	14.30	18.50	21.20
160	15	9.50	13.80	18.40	21.20
160	20	8.50	13.50	18.30	21.20
200	5	24.80	29.00	34.20	38.70
200	10	20.80	26.70	33.80	38.40
200	15	18.60	25.70	33.70	38.40
200	20	17.00	25.00	33.60	38.40

Table 75

For any further assistance call the ACO Building Drainage helpline on 01462 816666.

Operating pressure

The ACO PIPE® socketed stainless steel pipe systems are fitted with a unique, double lip seal manufactured from either EPDM or Viton®. The double lip seal arrangement provides added security for the ultimate in long term reliability.

The ACO PIPE® socketed stainless steel pipe systems are tested and approved for operating pressures in all gravity, syphonic and vacuum systems.

ACO PIPE® push fit stainless steel pipe systems are designed for maximum working pressure up to 0.5 bar. In cases where higher pressure may occur joints need to be locked with socket clamps.

Pipe diameter (mm)	Max. operating pressure (bar)	
	Without socket clamp	With socket clamp
50	0.5	2.0
75	0.5	2.0
110	0.5	2.0
160	0.5	1.0

Table 76

Installation guide

Generally

The following standards will assist designers select the correct size of pipe system for a particular application: BS EN 12056: gravity drainage systems inside buildings. BS EN 752: drain and sewer systems outside buildings. Installation should be in accordance with the manufacturer's recommendations but also BS EN 12056-2, BS EN 12056-3 and BS EN 752.

Pipe cutting

If it is necessary to adapt or shorten pipe lengths then whatever tools are used, the cut must be square, clean, ready chamfered and free from burrs. Suitable cutters and whole cutter sets are available from ACO (see page 46).

Pipe weights

Engineers should be aware of minimum and maximum weights when designing vertical stack and horizontal pipe run systems. Generally, when the pipe is completely full of water, then the vertical deflection of the pipe between brackets should not exceed 1.5mm. The discretion of the installer should be applied in each instance to ensure that the pipe is adequately supported.

As a guide, use the table below for bracket spacing on horizontal pipes.

Pipe Ø (mm)	Vertical Bracket Spacing (m)
50	2.0
75	2.3
110	2.5
125	2.5
160	2.5
200	2.5

Table 77

Horizontal pipe runs

Horizontal pipework should be supported with at least two brackets per 3 metre pipe length. Brackets should be within 300mm of the pipe joints and approximately at the midpoint of the pipe length, but not more than 2 metres from the next bracket. Additional brackets should be used at changes of direction and at junction points immediately downstream of the fitting. Where long pipe runs occur i.e. greater than 15 metres, a fixing arm should be attached to the bracket to prevent pendulum movement within the system.

Vertical pipe stacks

When designing a rainwater or soil and waste system, pipework must be supported and using the vertical bracket spacing in the table below should be fixed to the wall not less than 30mm to facilitate maintenance and painting. Allow at least one bracket per fitting preferably at the downstream end of the fitting with additional brackets at changes of direction or junction points.

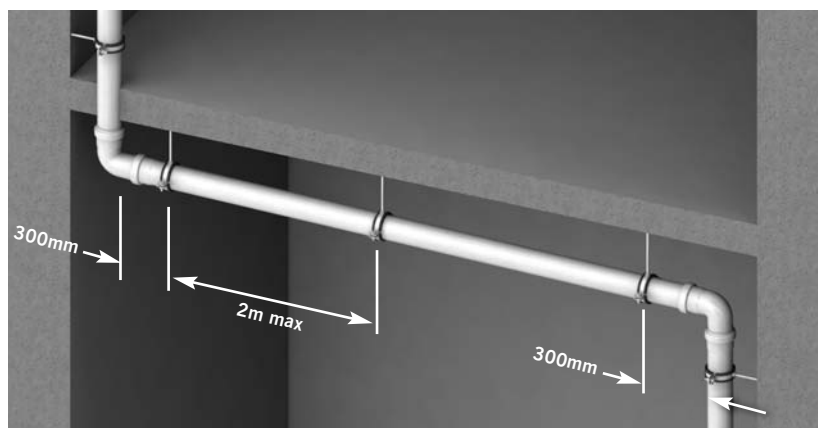
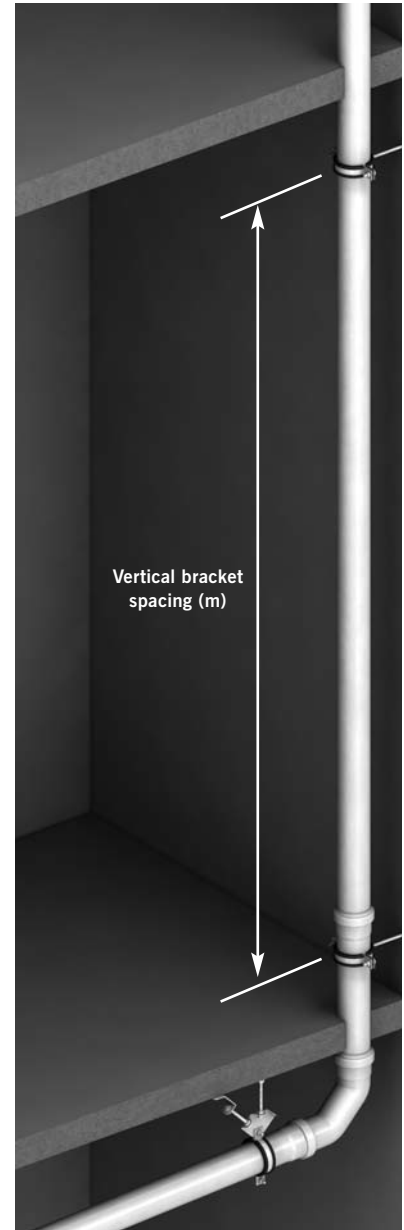

Installation guide

Pipe jointing

The assembly of pipe joints is quick and straightforward requiring only a light application of lubricant available from ACO to the chamfered pipe end. Ensure that the mating ends of the pipes and fittings are clean and free from contamination. Push-fit the pipe end into the socket but do not push fully home into the socket recess so as to allow for thermal expansion within the system.



Seal assembly

The double lip seal is easily removed and replaced from the female end of all pipes and fittings. This allows the on-site upgrade of seal material from EPDM or Viton without the need for special tools.

Seal installation notes

1. If changing the seal, ensure the correct size and grade of seal is selected for the application. For reference, EPDM seals are BLACK and Viton seals are GREEN. If in doubt, contact the ACO Building Drainage Helpline on 01462 816666 for assistance.
2. Ensure the seal itself and the zone around the pipe and/or fitting receiving the seal is clean, dry and free from dirt, dust or particulates.
3. Insert the dry seal into the pipe/fitting recess as shown in the diagram below.
NOTE: the seal MUST be inserted so the double sealing lips face away from the opening of the pipe/fitting.
4. Do not use tools to aid the assembly process otherwise damage to the pipes, fittings and seals may occur.

Seal integrity

Providing the installation guidelines are followed and that all reasonable precautions are taken during the installation and that the system is not exposed to chemicals or conditions outside the specification for the component materials, a life expectancy of around 25 years can be reasonably expected. No guarantees on seal integrity can be offered as the ACO Pipe® components are subjected to a variety of installation and in-service operational variables beyond the control of ACO Building Drainage.

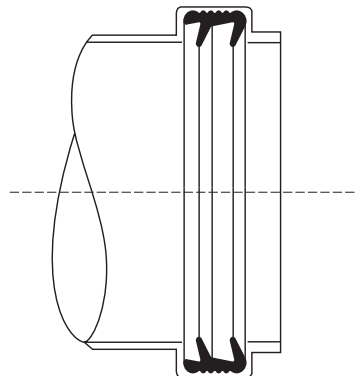

Installation guide

Below ground installation

Handling and care

ACO Pipe® thin-walled stainless steel pipe systems are vulnerable to damage if not treated with care during the installation process. The system must not be subjected to rough manual handling or knocks on site or during the installation process.

Back filling

The choice of bedding and backfilling depends on the depth at which the pipes are to be laid and the size and strength of the pipes. Selected fill, whether selected from locally excavated material or imported, shall consist of uniform, readily compacted material. Fill shall be free from vegetable matter, building rubbish and frozen material or materials susceptible to spontaneous combustion and shall exclude clay of liquid limit greater than 80 and/or plastic limit greater than 55 and materials of excessively high moisture content. Clay lumps and stones retained on 75mm and 37.5mm sieves respectively, shall be excluded from the fill material. All granular backfill materials shall pass through a 75 mm BS sieve. All granular backfill materials used in the reinstatement of trenches less than 150 mm wide shall pass through a 37.5 mm BS sieve.

Compaction

Sidefill should be placed evenly on both sides of the pipe, and compacted in accordance with the project specification. Single-sized coarse granular materials, such as stone or gravel, may achieve the necessary density without compaction. Compaction of these materials is recommended where trench walls are relatively soft and weak. For well-graded granular soils compaction will be necessary. It is important that compacting equipment does not come into contact with the pipe at any stage of compaction. The sidefill material should normally extend a minimum 100mm above the pipe crown. Backfill material within 300mm of the pipe crown should be free from material exceeding 40mm diameter. Heavy compaction should not be applied until pipe cover is a minimum of 300mm. Backfill material placed more than 300mm above the pipe crown should be placed and compacted in layers not greater than 300mm thick or in accordance with the project specification. Trench support, where employed, is to be removed progressively prior to compaction of side and backfill.

Local standards

Pipe installation should be in accordance with the requirements of BS EN 12056:2000 Gravity drainage systems inside buildings (various parts) and The Building Regulations 2010 Part H.

Socket clamps

Drainage systems for soil, waste water and rainwater in above-ground installations are gravity systems with free draining and should not be overloaded/blocked. The ACO PIPE® socketed systems have push-fit socket joints and consequently will not be able to resist internal pressure unless precautions are taken to ensure that the joints will not slide apart.

Appropriate fixing to the building can prevent the joints from sliding apart in most cases, but if it is difficult or impossible to fix the pipes to the building, the socket clamps (Part No. 419134–7) can prevent the push-fit sockets and spigot ends from sliding apart if the system is overloaded or internal pressure is generated.

Installation guide



Pipe Ø (mm)	Max. pressure (bar)
50mm	2.0
75mm	2.0
110mm	2.0
160mm	1.0

Table 78

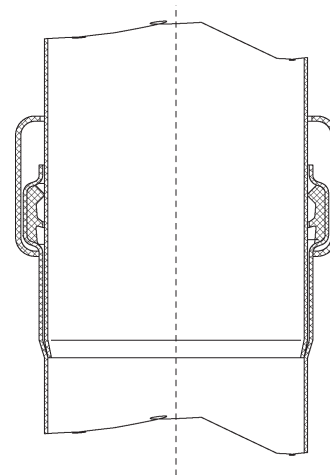

The ACO PIPE® socketed joints with the socket clamps can withstand the pressures presented in the Table 76.

ACO PIPE® material information

Pipe material information

Thermal movement

ACO PIPE® stainless steel pipework systems have a low coefficient of thermal expansion, of approximately 1 in 1000mm per 60°C of temperature change.

The requirement for thermal tolerance on pipe systems is otherwise confined to hot water conditions. A comparison of approximate thermal movement between different pipe materials inmm per metre with a temperature change of 60°C is given below.

- Aluminium alloy 1.44mm
- Copper 0.98mm
- Grey cast iron 0.75mm
- HDPE 9.0mm
- PVCu 3.0mm
- Stainless steel 0.99mm

Coefficients of linear expansion (α) for various materials are as follows:

Material	Coefficient of linear expansion ($10^{-6}K^{-1}$)
HDPE	150.0
PVCu	50.0
Aluminium	24.0
Stainless steel	16.5
Copper	16.4
Grey cast iron	12.5

Table 79

Pipe weights

ACO PIPE® thin-wall stainless steel pipe systems are light in weight and high on performance with clear advantages in ease of handling and savings in labour costs over traditional metal pipe systems.

Engineers will need to know weights and loading when designing vertical stack and horizontal pipe run systems. The table below gives weights for all pipe sizes empty and full of water.

Pipe diameter (mm)	Pipe weight Empty (kg/m)	Pipe weight full (water) (kg/m)
50	1.2	3.0
75	1.8	6.9
110	2.7	11.9
125	3.3	15.8
160	5.0	24.6
200	7.5	38.0

Table 80

Wall thickness

Pipe wall thicknesses - up to Ø125mm: 1mm; Ø160mm: 1.25mm; Ø200mm: 1.5mm.

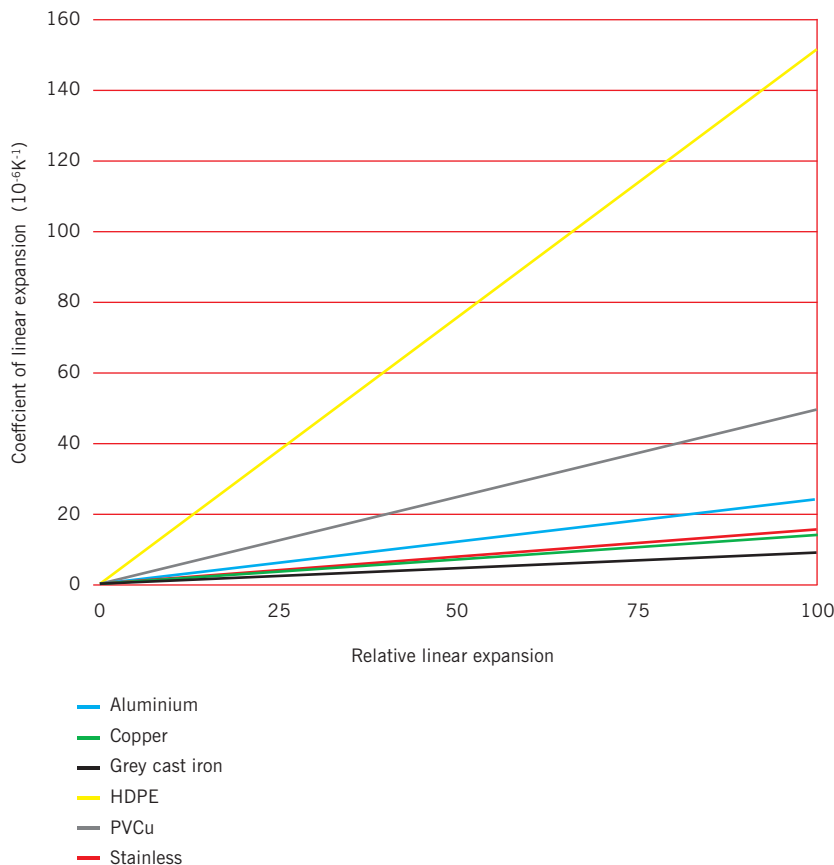

ACO PIPE® material information

Seal material information

The ACO PIPE® socketed stainless steel pipe systems are fitted with a unique, double lip seal manufactured from either EPDM or Viton®. The double lip seal arrangement provides added security for the ultimate in long term reliability.

EPDM (Ethylene Propylene Diene Monomer)
EPDM was originally developed in the 1950's for vehicle tyre applications. It reached wider applications because of its suitability for outdoor use.

Properties include:

- ✓ The most water-resistant type of rubber - also very resistant to most water based chemicals.
- ✓ Inert structure and remains stable over long periods of time.
- ✓ Withstands elevated temperatures up to 130°C for extended periods (months).
- ✓ Easily compounded and processed.

Limitations

- ✗ Not resistant to oil or oil based products.

Viton*

Viton* is a fluorocarbon and the best material for resistance to hostile chemical and oil environments at normal and elevated temperatures. This material is widely used in the chemical and pharmaceutical industries, however is significantly more expensive than EPDM.

Properties include:

- ✓ Good resistance to water.
- ✓ Good resistance to oils, fuels and most chemicals.

Limitations

- ✗ Not resistant to ketone solvents.

** Du Pont Registered Trade Mark.*



Property			EPDM	Viton*
Water resistance			Excellent	Good
Chemical resistance	Acids		Good	Excellent
	Bases		Good	Good
Solvent resistance (20°C)	Alcohol		Good	Good
	Acetone		Good	Unsuitable
	Benzene		Unsatisfactory	Good
Oil resistance	ASTM Oil No 1	@ 20° C	Fair	Excellent
		@ 100° C	Unsatisfactory	150°C Excellent
	ASTM Oil No 3	@ 20° C	Unsatisfactory	Excellent
		@ 100° C	Unsatisfactory	150°C Excellent
Fuel resistance	ASTM B	@ 20° C	Unsatisfactory	Excellent
Resistances	Oxidation		Excellent	Outstanding
	Ozone and weathering		Outstanding	Outstanding
Heat resistance	Maximum continuous		130°C	205°C
	Maximum intermittent		150°C	300°C
Low temperature resistance			-50°C	-20°C
Gas permeability			Fairly low	Very low
Physical strength			Good	Good
Compression set resistance			Good	Good
Tear and abrasion resistance			Good	Good
Cost factor			1	20

Table 81

Care and maintenance

Maintenance programme

With care taken during the fabrication and installation, cleaning before handing over to the client should present no special problems, although more attention than normal may be required if the installation period has been prolonged.

Where surface contamination is suspected, immediate attention to cleaning after site fixing will encourage a trouble-free product.

Food and beverage handling, pharmaceutical and chemical industry applications require extremely high levels of cleanliness applicable to each industry.

Advice is often sought concerning the frequency of cleaning stainless steel and the answer is quite simple - clean the metal whenever it becomes dirty in order to restore its original appearance. This may vary from one to four times per year for external applications or it may be once per day for products installed in hygienic or chemically aggressive applications.

Frequency and cost of cleaning is lower with stainless steel than with many other materials and will often outweigh the initial higher cost of this superior product.

Stainless steel is easy to clean. Washing with soap or mild detergent in warm water followed by a clear water rinse is usually quite adequate for many industrial applications. An enhanced aesthetic appearance will be achieved if the cleaned surface is finally wiped dry.

Precautions

Acids should ONLY be used for on-site cleaning when all other methods have been proved unsatisfactory and in accordance with manufacturers' instructions. Appropriate personal protection equipment should be used at all times.

Care should be taken to ensure that acid cleaners do not spill over adjacent areas. Solvents should not be used in confined areas without adequate ventilation and only in accordance with manufacturers' instructions.

Conclusion

If all the cleaning suggestions and actions in the table below have been attempted and the surface is still not satisfactory, stainless steel can be mechanically cleaned or electropolished by specialists on site. For further information, contact the ACO Building Drainage Helpline on 01462 816666 for help and assistance.

Problem	Cleaning Agent	Comments
Routine cleaning.	Soap or mild detergent (e.g. washing up liquid) and water.	Sponge, rinse with clean water. Wipe dry if necessary.
Fingerprints.	Soap and warm water or organic solvent (e.g. alcohol, acetone).	Rinse with clean water, wipe dry if necessary.
Stubborn stains and discolouration.	Mild cleaning solutions (e.g. Cif, GODDARD'S STAINLESS STEEL CARE).	Rinse well with clean water and wipe dry.
Oil and grease marks.	Organic solvent (e.g. alcohol, acetone).	Clean after with soap and water, rinse with clean water and dry.
Rust and other corrosion products.	Oxalic acid. The cleaning solution should be applied with a swab and allowed to stand for 15-20 minutes before being washed away with clean water. May continue using Cif to give final clean.	Rinse well with clean water. Precautions for acid cleaners must be observed.

Table 82

Note: Always read instructions on proprietary cleaning agents

Material resistance chart

The resistance information contained within this table is indicative only.

All data is based on reactions noted at an ambient temperature of 20°C. Higher temperatures will generally reduce the corrosion resistance of the materials.

Please contact ACO if guarantees are required of specific material suitability.

We shall arrange for tests to be undertaken with the reagent to establish the chemical resistance of the materials.

Legend

- ✓ Recommended.
- ? Suitable.
However, contact ACO for further advice.
- ✗ Not recommended.
- ~ No data available

Reagent	Stainless Steel 304	Stainless Steel 316	EPDM	Viton
Acetic Acid 20%	✓	✓	✓	✓
Acetic Acid 80%	✓	✓	✓	✓
Acetone	✓	✓	✓	✗
Alcohol (Methy or Ethyl)	✓	✓	✓	?
Aluminium Chloride	?	?	✓	✓
Aluminium Sulphate	✓	✓	✓	✓
Ammonia Gas (Dry)	✓	✓	~	~
Ammonium Chloride	?	?	✓	✓
Ammonium Hydroxide	✓	✓	✓	✓
Ammonium Nitrate	✓	✓	✓	✓
Ammonium Phosphate	✓	✓	✓	✓
Ammonium Sulphate	?	✓	✓	✓
Ammonium Sulphide	✓	✓	~	~
Amyl Chloride	✓	✓	✗	?
Aniline	✓	✓	?	✓
Barium Chloride	✓	✓	✓	✓
Barium Hydroxide 10%	~	~	✓	✓
Barium Sulphate	✓	✓	✓	✓
Barium Sulphide	~	~	✓	✓
Beer	✓	✓	✓	✓
Beet Sugar Liquors	✓	✓	✓	✓
Benzene	✓	✓	✗	✓
Benzoic Acid	✓	✓	✗	✓
Bleach - 12.5% Active Cl	~	~	✓	✗
Boric Acid	✓	✓	✓	✓
Bromic Acid	?	?	~	~
Bromine Water	✗	✗	~	~
Butane	✓	✓	✗	✓
Calcium Carbonate	✓	✓	✓	✓
Calcium Chloride	✗	?	✓	✓
Calcium Hydroxide	?	✓	✓	✓
Calcium Hypochlorite	✗	?	?	✓
Calcium Sulphate	✓	✓	✓	✓
Cane Sugar Liquors	~	~	✓	✓
Carbonic Acid	~	~	✓	✓
Carbon Bisulphide	✓	✓	✗	✓
Carbon Dioxide	✓	✓	✓	✓
Carbon Monoxide	✓	✓	✓	✓
Carbon Tetrachloride	?	?	✗	✓

Reagent	Stainless Steel 304	Stainless Steel 316	EPDM	Viton
Caustic Potash	✓	✓	✓	✓
Caustic Soda 20%	✓	✓	✓	✓
Caustic Soda 50%	✓	✓	✓	✓
Caustic Soda 80%	✓	✓	✓	✓
Chlorine (Dry)	?	?	✓	✓
Chlorine (Wet)	✗	✗	✗	✓
Chloroacetic Acid	?	✓	?	✗
Chlorobenzene	✓	✓	✗	✓
Chloroform	?	?	✗	✓
Chromic Acid 50%	✗	✗	?	✓
Chromic Acid 10%	✓	✓	✗	?
Citric Acid	?	✓	✓	✓
Copper Chloride	✗	✗	✓	✓
Copper Cyanide	✓	✓	✓	✓
Copper Nitrate	✓	✓	~	✓
Copper Sulphate	✓	✓	✓	✓
Cottonseed Oil	~	~	✗	✓
Cresol	~	~	✗	✗
Cyclohexanone	?	✓	✗	✗
Cyclohexane	✓	✓	✗	✓
Diethylamine	?	?	?	✗
Disodium Phosphate	~	~	✓	✓
Distilled Water	✓	✓	✓	✓
Ethyl Acetate	✓	✓	?	✗
Ethylene Chloride	✓	✓	✗	?
Ethylene Glycol	✓	✓	✓	✓
Fatty acids (Cb)	✓	✓	✗	✓
Ferric Sulphate	✓	✓	✓	✓
Fluorene Gas (Wet)	✗	✗	✓	?
Formaldehyde 37%	✓	✓	✓	✓
Formic Acid 90%	✗	✓	✓	?
Freon 12	✓	✓	✓	✓
Fruit Juices & Pulp	?	✓	~	✓
Furfural	✓	✓	✗	✗
Gasoline (Refined)	✓	✓	✗	✓
Glucose	✓	✓	✓	✓
Glycerine	✓	✓	✓	✓

Table 83

Material resistance chart

Reagent	Stainless Steel 304	Stainless Steel 316	EPDM	Viton
Hydrobromic Acid 20%	✗	✗	✓	✓
Hydrochloric Acid 40%	✗	✗	✗	✓
Hydrocyanic Acid	✓	✓	?	✓
Hydrogen Peroxide 90%	✓	✓	✗	✓
Hydroquinone	~	~	✗	✓
Hypochlorous Acid (Chlorine Water)	~	~	✗	✓
Iodine	✗	?	?	✓
Kerosene	✓	✓	✗	✓
Lactic Acid 25%	✓	✓	✓	✓
Linseed Oil	✓	✓	✗	✓
Magnesium Chloride	?	?	✓	✓
Magnesium Sulphate	✓	✓	✓	✓
Maleic Acid	?	?	✗	✓
Methyl Chloride	?	?	✗	✗
Methyl Ethyl Ketone	~	~	✓	✗
Milk	✓	✓	✓	✓
Minerals Oils	~	~	✗	✓
Nickel Chloride	?	?	✓	✓
Nickel Sulphate	✓	✓	✓	✓
Oils and Fats	✓	✓	✗	✓
Oleic Acid	✓	✓	✓	✓
Oleum	~	~	✗	✓
Oxalic Acid	?	?	✓	✓
Palmitic Acid 10%	~	~	✓	✓
Perchloric Acid 10%	✗	✗	?	✓
Perchloric Acid 70%	✗	✗	?	✓
Petroleum Oils	✓	✓	✗	✓
Phenol 5%	✓	✓	?	✓
Phosphorous Trichloride	✓	✓	✓	✓
Photographic Solutions	?	?	✓	✓
Picric Acid	✓	✓	✓	✓
Plating Solutions	~	~	~	✓
Potassium Carbonate	✓	✓	✓	✓
Potassium Chloride	✓	✓	✓	✓
Potassium Cyanide	✓	✓	✓	✓
Potassium Dichromate	✓	✓	✓	✓
Potassium Hydroxide	✓	✓	✓	✓
Potassium Permanganate	✓	✓	✓	✓
Potassium Sulphate	✓	✓	✓	✓
Propane Gas	~	~	~	✓
Propyl Alcohol	~	~	✓	✓
Sea Water (Natural)	✗	?	✓	✓
Silver Nitrate	✓	✓	✓	✓

Reagent	Stainless Steel 304	Stainless Steel 316	EPDM	Viton
Silver Sulphate	✓	✓	✓	✗
Sodium Bicarbonate	✓	✓	✓	✓
Sodium Bisulphite	✓	✓	✓	✗
Sodium Carbonate	✓	✓	✓	✓
Sodium Cyanide	✓	✓	✓	✓
Sodium Ferrocyanide	~	~	?	✓
Sodium Hydroxide	✓	✓	✓	✓
Sodium Hypochlorite	?	✓	?	✓
Sodium Sulphate	✓	✓	✓	✓
Sodium Sulphide	?	✗	✓	✓
Sodium Sulphite	?	✓	✓	✓
Sodium Thiosulphate	✓	✓	✓	✓
Stannous Chloride	?	?	✗	✓
Stearic Acid	✓	✓	?	✓
Sulphurous Acid	?	✓	?	✓
Sulphur	?	✓	~	✓
Sulphur Dioxide (Dry)	?	✓	✓	✓
Sulphur Dioxide (Wet)	?	✓	✓	✓
Sulphuric Acid 50%	✗	✗	?	✓
Sulphuric Acid 70%	✗	✗	?	✓
Sulphuric Acid 93%	✗	✗	?	✓
Tannic Acid	✓	✓	✓	✓
Tanning Liquors	✓	✓	✓	✓
Tartaric Acid	~	~	?	✓
Toluene	~	~	✗	✗
Trichloroethylene	✓	✓	✗	✗
Triethylamine	✓	✓	✓	✗
Trisodium Phosphate	~	~	✓	✓
Turpentine	✓	✓	✗	✓
Urea	✓	✓	✓	✓
Urine	✓	✓	✓	✓
Vinegar	✓	✓	✓	✓
Water (Fresh)	✓	✓	✓	✓
Water (Mine-acid)	✓	✓	✓	✓
Water (Salt)	~	~	✓	✓
Whisky	✓	✓	✓	✓
Wines	✓	✓	✓	✓
Xylene	~	~	✗	✗
Zinc Chloride	✗	✗	✓	✓
Zinc Sulphate	?	✓	✓	✓

Table 84



Notes



ACO Technologies plc

- ACO Building Drainage
- ACO Water Management
Civils + Infrastructure
Urban + Landscape
- ACO Sport
- ACO Wildlife
- ACO Technic
- ACO Home & Garden

ACO Building Drainage

A division of ACO Technologies plc
ACO Business Centre
Caxton Road
Bedford
Bedfordshire
MK41 0LF
Tel: 01462 816666
Fax: 01462 851490

e-mail: buildingdrainage@aco.co.uk
www.acobuildingdrainage.co.uk

The ACO Group: A strong family you can depend on.

© March 2012 ACO Technologies plc. All reasonable care has been taken in compiling the information in this document. All recommendations and suggestions on the use of ACO products are made without guarantee since the conditions of use are beyond the control of the Company. It is the customer's responsibility to ensure that each product is fit for its intended purpose, and that the actual conditions of use are suitable. This brochure and any advice is provided by ACO Technologies plc (the Company) free of charge and accordingly on terms that no liability including liability for negligence will attach to the Company or its servants or agents arising out of or in connection with or in relation to this brochure or any such advice. Any goods supplied by the Company will be supplied solely upon its standard conditions of sale, copies of which are available on request. The Company's policy of continuous product development and improvement renders specifications liable to modification. Information provided in this brochure is therefore subject to change without prior notification.

